

Blue Brute Pipe

4" - 12" (100mm - 300mm)

Designed for municipal applications, Blue Brute® systems deliver superior strength with corrosion resistant performance and the ability to flex without damage. IPEX municipal pressure piping systems are made with a high-strength, high-impact PVC compound, allowing them to perform even under high traffic loads and deep burial conditions.



Corrosion-Proof Performance

IPEX Blue Brute systems are immune to corrosion from aggressive soils and galvanic action.

Superior Hydraulics

The glass-like finish of PVC reduces friction losses and eliminates the tuberculation common in iron pipes. As a result, pumping costs are reduced and water quality is maintained.

Cast Iron Outside Diameter (CIOD)

Blue Brute systems are manufactured with a cast iron outside diameter (CIOD). This is compatible with waterworks valves, appurtenances and restrainers.

Bottle-tight Joints, Removable Gaskets

IPEX's patented gasket system not only withstands many times the rated system pressure, but also withstands full vacuum pressures. The unique removable gasket system allows special oilresistant(nitrile) gaskets to be easily installed when working in contaminated soils.

Third-party Certification

All IPEX municipal systems are third-party certified as applicable. In addition, IPEX Blue Brute systems have Factory Mutual approval and Underwriter's Laboratories (ULI and ULC) listings.



Volume I: Pressure Piping Systems Design

Municipal Technical
Manual Series

SECOND EDITION

Blue Brute® Piping Systems
IPEX Centurion® Piping Systems
CycleTough® Piping Systems
TerraBrute® Piping Systems
Q-Line® Water Service Tubing



IPEX

We Build Tough Products for Tough Environments®

IPEX Pressure Piping Systems Design

Municipal Technical Manual Series

Vol. 1, 2nd Edition

© 2009 by IPEX. All rights reserved. No part of this book may be used or reproduced in any manner whatsoever without prior written permission. For information contact: IPEX Management Inc., 2441 Royal Windsor Drive, Mississauga, Ontario, Canada, L5J 4C7.

The information contained here within is based on current information and product design at the time of publication and is subject to change without notification. IPEX does not guarantee or warranty the accuracy, suitability for particular applications, or results to be obtained therefrom.



ABOUT IPEX

At IPEX, we have been manufacturing non-metallic pipe and fittings since 1951. We formulate our own compounds and maintain strict quality control during production. Our products are made available for customers thanks to a network of regional stocking locations throughout North America. We offer a wide variety of systems including complete lines of piping, fittings, valves and custom-fabricated items.

More importantly, we are committed to meeting our customers' needs. As a leader in the plastic piping industry, IPEX continually develops new products, modernizes manufacturing facilities and acquires innovative process technology. In addition, our staff take pride in their work, making available to customers their extensive thermoplastic knowledge and field experience. IPEX personnel are committed to improving the safety, reliability and performance of thermoplastic materials. We are involved in several standards committees and are members of and/or comply with the organizations listed on this page.

For specific details about any IPEX product, contact our customer service department (contact information is listed on the back cover).

CONTENTS

Pressure Piping Systems Design Manual

About IPEX

Overview	1
----------------	---

Section One: Product Information

Introduction	3
--------------------	---

Summary of Pressure Pipe and Fittings Testing	3
---	---

Blue Brute® Piping Systems	4
---	---

Applications	4
--------------------	---

Gasket Options	5
----------------------	---

Standards	5
-----------------	---

Short Form Specifications	5
---------------------------------	---

Dimensions	6
------------------	---

IPEX Centurion® Piping Systems	10
---	----

Applications	10
--------------------	----

Pressure Ratings	11
------------------------	----

Surge Pressures	11
-----------------------	----

Gravity Applications	12
----------------------------	----

Standards	12
-----------------	----

Short Form Specifications	12
---------------------------------	----

Dimensions	13
------------------	----

CycleTough® Piping Systems	14
---	----

Applications	14
--------------------	----

Pressure Ratings	15
------------------------	----

Standards	15
-----------------	----

Short Form Specifications	15
---------------------------------	----

Dimensions	16
------------------	----

TerraBrute® Restrained Joint Pipe	23
--	----

Applications	23
--------------------	----

Pulling Forces	24
----------------------	----

Bending Forces	24
----------------------	----

Standards	26
-----------------	----

Short Form Specifications	26
---------------------------------	----

Dimensions	26
------------------	----

Q-Line® Water Service Tubing	27
---	----

Applications	27
--------------------	----

Pressure Ratings	28
------------------------	----

Flow Rates	28
------------------	----

Codes and Standards	29
---------------------------	----

	Short Form Specifications	29
	Dimensions	29
	Standards for PVC Pressure Systems	30
Section Two:	Properties of PVC Pressure Pipe and Pressure System Design	
	Introduction	31
	Material Properties of PVC	31
	Design Life	31
	Design Strength	32
	Chemical Permeation and Installation of PVC Pipe in Contaminated Soils	32
	Thermal Effects and UV Resistance	33
	Expansion and Contraction	33
	Design Calculations	
	Calculating a Pressure Rating	34
	Calculating a Pressure Class	34
	Calculating Friction Headloss	34
	Calculating Surge Pressures	35
	Calculating Wave Velocity	36
	Air Entrapment in Pipelines	36
	Cyclic Fatigue in PVC Pipes	38
	Thrust Restraint in Gasketed Piping Systems	38
	Assembly, Installation and Testing of PVC Pressure Pipe Systems	41
Section Three:	Design Examples	
	Hydraulic and Cyclic Design Example	43
	Transmission Pipe Design Example	46
Section Four:	Appendices	
	Appendix A: References	53
	Appendix B: Reference Tables and Conversion Charts	55
	Appendix C: Useful Formulas	60
	Appendix D: Abbreviations	62
	Appendix E: Tables and Figures	63

OVERVIEW

IPEX Inc. is one of the largest manufacturers of plastic piping systems in North America. IPEX manufactures piping systems for many different applications, including sewer and water supply, electrical and telecommunications systems, plumbing, industrial as well as radiant heating systems.

This design manual covers the technical aspects of designing pressure pipe systems with PVC pipe. More specifically, municipal potable water systems, as well as irrigation and sewer force main systems are described.

The manual is organized into three sections:

Section 1 deals with specific products and includes detailed information on applications, dimensions and applicable standards for each system.

Section 2 deals with general design issues associated with PVC systems such as hydraulics, cyclic design and other topics that are applicable to all the products described in the manual.

Section 3 consists of design examples that apply the concepts from the first two sections.

This manual is designed for Engineers, Technologists and other municipal infrastructure professionals who require a deeper understanding of municipal piping systems than can be gleaned from the more general overview literature available from IPEX.

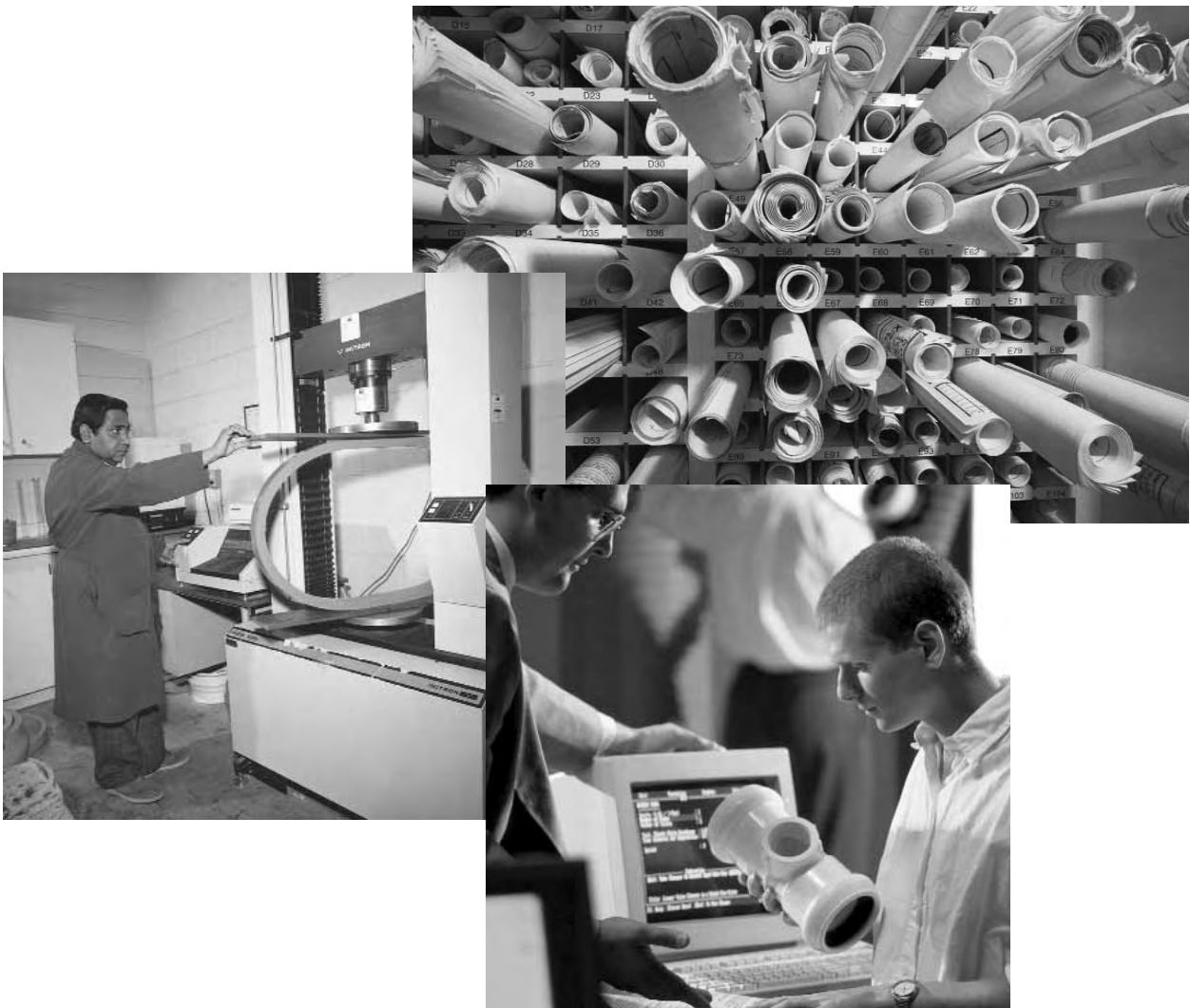



SECTION ONE: PRODUCT INFORMATION

INTRODUCTION

IPEX offers a number of different pressure piping systems that are used for various applications. While they are all plastic systems, they vary in outside diameter configurations and in available pressure ratings.

The products offered are:

Blue Brute® and **IPEX Centurion®** Piping Systems – Cast iron outside diameter (CIOD) pipe and fittings

CycleTough® Piping Systems – Iron Pipe Size outside diameter (IPSOD) pipe and fittings

TerraBrute® Pipe – CIOD pipe modified for use with trenchless installation methods such as directional drilling or pipe bursting

Q-Line® Water Service Tubing – 3/4" and 1" composite pipe designed for use as a water service to connect houses to main lines.

SUMMARY OF PRESSURE PIPE AND FITTINGS TESTING

All IPEX pressure pipes and fittings are manufactured to standards from various recognized organizations such as the AWWA, CSA, ASTM and others. As a result, all pressure pipe products undergo a variety of testing and quality procedures.

Blue Brute, IPEX Centurion, and TerraBrute Piping Systems

These piping systems are manufactured under various AWWA standards, including AWWA C900 (Blue Brute and TerraBrute), and AWWA C905 (IPEX Centurion). Fittings are manufactured under the C900, C905 and C907 standards.

Each length of Blue Brute, IPEX Centurion and TerraBrute pipe is hydrostatically tested in order to verify the pressure capabilities of each pipe as dictated by AWWA C900 and C905. In addition, burst tests are carried out regularly to verify the integrity of the pipe and joint system. It should be remembered that the hydrostatic test is done using the pipe's own gasket, which means that both the pipe and the joining system are being checked. AWWA standards also require a number of other tests, including impact tests at room temperature.

TerraBrute pipe does not strictly comply with AWWA C900/905 standards because of the dimensional change imposed by the grooving procedure, however it is tested using the same procedures as conventional Blue Brute and IPEX Centurion. The hydrostatic proof test is carried out on each length of TerraBrute to the same pressures and durations as for standard Blue Brute or IPEX Centurion.

In addition to AWWA requirements, CSA certification requires very stringent testing and QA/QC procedures. For example, the CSA B137.3 standard dictates that a vacuum test be performed on samples of pipe joints to verify that they can withstand a vacuum pressure of -10.8 psi. (Further tests have been performed by IPEX that simulate full vacuum pressures combined with external groundwater pressure of over 100 psi with no leakage).

CSA certification also requires impact testing to be carried out at 0°C (32°F), which is a much tougher test compared to the room temperature testing required by the AWWA. This is an example of how one standard can have significantly tougher testing requirements than another.

In addition to the pressure and impact testing, the material itself is tested by using acetone immersion tests and heat reversion tests. Both tests are used to check that the proper degree of fusion has occurred during the extrusion process.

The dimensional characteristics of each pipe and fitting are checked constantly during the extrusion and molding processes, and samples are taken for detailed dimensional analysis during each extrusion or molding run.

CycleTough (IPSOD) Pipe

CycleTough pipe undergoes testing identical to that of IPEX Centurion pipe with the exception of the hydrostatic proof test of each length of pipe. This does not mean that the pipe is of any lesser quality than Blue Brute or IPEX Centurion pipe – it only means that it is manufactured under a different standard (ASTM D2241) that does not require the hydrostatic proof test.

In addition to performance and dimensional checks, National Sanitation Foundation (NSF) requirements mean that all products are thoroughly tested to ensure they have no effect on potable water.

To summarize – There are many standards governing the manufacture and design of IPEX pressure pipes and fittings. IPEX also has internal testing standards that are often well in excess of published requirements to ensure acceptable performance on the jobsite.

BLUE BRUTE® PIPING SYSTEMS

Blue Brute is one of the most well known names in municipal water supply, as it has built up an enviable reputation for performance and reliability over the years. Blue Brute pipe and fittings eliminate the threat of corrosion, while providing reliable long-term service. While Blue Brute pipe is compatible with iron fittings, IPEX recommends the use of Blue Brute fittings as they are made to match the pipe, and eliminate the “Achilles heel” of many systems – corroding iron fittings.

It is advisable to specify pipe and fittings from the same manufacturer in order to ensure a completely matched system. For example, many competing PVC injection molded fittings are manufactured with PVC compound with a lower hydrostatic design basis than the pipe. Only by specifying Blue Brute fittings can you ensure that the fittings have the same 4000 psi long term strength as the pipe itself.



Applications:

Municipal water distribution systems and fire lines.
Irrigation, sewage forcemains, industrial lines.



BLUE BRUTE® PIPING SYSTEMS CONT'D

Gasket Options For Contaminated Soils

Blue Brute pipe and fittings have removable gaskets. This allows oil resistant (nitrile) gaskets to be easily substituted when installing piping systems in contaminated soils (please refer to Section 2 – Chemical Permeation and Resistance for more information on this topic)

Standards:

Blue Brute Pipe:

AWWA C900, CSA B137.3, Factory Mutual, ULC and ULI Approved, NSF-61, Certified to NQ 36240-250



Blue Brute Fittings:

AWWA C907, CSA B137.2 (100mm – 200mm), AWWA C900, CSA B137.3 (250mm-300mm), Factory Mutual, ULC and ULI Approved



Short Form Specifications

General

Blue Brute pipe shall conform to AWWA C900 “Poly (Vinyl Chloride) (PVC) Pressure Pipe (4" - 12") for Water,” and certified to CSA B137.3 “Rigid Poly (Vinyl Chloride) (PVC) Pipe for Pressure Applications.” Blue Brute DR25 shall have a pressure class of 690 kPa (100 psi). DR18 pipe shall have a pressure class of 1,034 kPa (150 psi). DR14 pipe shall have a pressure class of 1,379 kPa (200 psi).

Material

Blue Brute pipe shall be made from clean, 12454B PVC compound, conforming to ASTM resin specification D1784.

Product

Pipe shall be suitable for use at maximum hydrostatic working pressures equal to the class designation at 23°C (73°F). Laying lengths shall be 6.1 meters (20 feet). Pipe shall have cast-iron outside diameters. Every length must be proof tested at four times the pressure.

Joining

The gasket shall be carefully fitted to the bell groove if not already factory installed. Both bell and spigot shall be clean and free of debris before approved lubricant is applied. The pipe and/or fittings shall be joined by push-fitting bell and spigot joint to the depth line marked on the spigot. When pipe has been cut in the field, the end shall be made square and beveled to a 15° chamfer. All insertion lines should be re-drawn, according to the IPEX Pressure Pipe Installation Guide.

Molded Fittings

Blue Brute fittings shall conform to AWWA C907 “Polyvinyl Chloride (PVC) Pressure Fittings for Water (4" through 8)” and be certified to CSA B137.2 “PVC Injected Molded Gasketed Fittings for Pressure Applications.” They shall also be UL Listed and FM approved.

Fabricated Fittings

Fabricated fittings shall be made from segments of AWWA C900 Class 150 PVC pipe bonded together and over-wrapped with fiberglass-reinforced polyester. The pressure class must match the pipe. The fittings must meet the requirements of CSA B137.3.

Lubricant

Pipe must be assembled with IPEX non-toxic, water soluble lubricant listed by the National Sanitation Foundation.

Colour Coding

Water pipe and fittings shall be colour coded blue.

BLUE BRUTE® PIPING SYSTEMS CONT'D

Dimensions:

Blue Brute pipes and fittings are manufactured with cast iron outside diameters (CIOD), which means that they are compatible with much of the existing infrastructure of older iron pipes. This means that no special transition fittings are needed with Blue Brute.

Size		*Class 100 (DR25)						Class 150 (DR18)						Class 200 (DR14)					
		Avg. ID		Min. Wall Thickness		Avg. OD		Avg. ID		Min. Wall Thickness		Avg. OD		Avg. ID		Min. Wall Thickness		Avg. OD	
in	mm	in	mm	in	mm	in	mm	in	mm	in	mm	in	mm	in	mm	in	mm	in	mm
4	100	4.42	112	0.192	5	4.80	122	4.27	108	0.267	7	4.80	122	4.11	104	0.343	9	4.80	122
6	150	6.35	161	0.276	7	6.90	175	6.13	155	0.383	10	6.90	175	5.91	149	0.493	13	6.90	175
8	200	8.33	212	0.362	9	9.05	230	8.05	204	0.502	13	9.05	230	7.76	198	0.646	16	9.05	230
10	250	10.21	260	0.444	11	11.10	282	9.87	250	0.616	16	11.10	282	9.51	242	0.793	20	11.10	282
12	300	12.15	309	0.527	13	13.20	335	11.73	297	0.733	19	13.20	335	11.31	287	0.943	24	13.20	335

* Pressure class includes a 2:5:1 safety factor and a 2 ft/s surge allowance.

90° Elbow

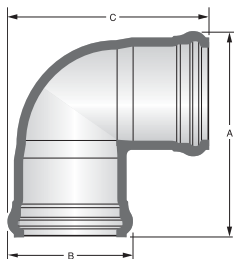

SIZE		A		B		C	
in	mm	in	mm	in	mm	in	mm
4	100	10.14	257	6.25	159	10.14	257
6	150	13.90	353	8.88	226	13.90	353
8	200	16.90	430	11.36	289	16.90	430

45° Elbow

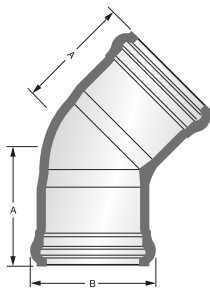

SIZE		A		B	
in	mm	in	mm	in	mm
4	100	5.63	143	6.27	159
6	150	7.56	192	8.80	225
8	200	8.80	224	11.30	287

BLUE BRUTE® PIPING SYSTEMS CONT'D

PRODUCT INFORMATION

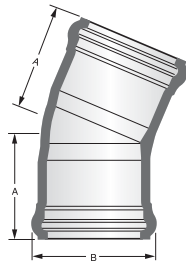

22½° Elbow

SIZE		A		B	
in	mm	in	mm	in	mm
6	150	6.82	173	8.84	225
8	200	7.90	200	11.30	287

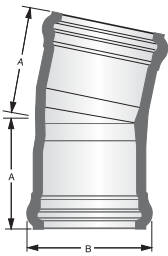

11¼° Elbow

SIZE		A		B	
in	mm	in	mm	in	mm
6	150	6.45	164	8.84	225
8	200	7.48	190	11.30	287

Reducing Adapter Spigot x Bell



SIZE		A		B	
in	mm	in	mm	in	mm
6 x 4	150 x 100	5.8	147	4.3	109
8 x 6	200 x 150	12.5	318	5.5	140
10 x 8	250 x 200	7.3	185	5.8	147
12 x 10	300 x 250	10.1	256	6.5	165

Coupling (available without centerstop as a Repair Coupling)

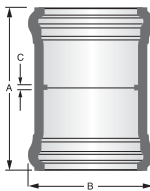

SIZE		A		B		C	
in	mm	in	mm	in	mm	in	mm
4	100	8.18	207	6.27	160	0.25	7
6	150	12.11	307	8.88	225	0.25	7
8	200	13.58	345	11.35	288	0.25	7
10	250	18.12	460	14.30	363	0.50	13
12	300	19.40	493	17.30	439	0.50	13

BLUE BRUTE® PIPING SYSTEMS CONT'D

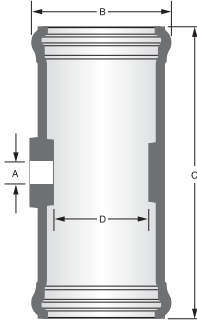

Single Tapped Coupling

SIZE		A		B		C		D	
in	mm	in	mm	in	mm	in	mm	in	mm
4 x 4 x	100 x 100 x	3/4	20	6.27	159	10.20	259	4.43	113
4 x 4 x	100 x 100 x	1	25	6.27	159	10.20	259	4.43	113
6 x 6 x	150 x 150 x	3/4	20	8.74	222	14.38	365	6.06	154
6 x 6 x	150 x 150 x	1	25	8.74	222	14.38	365	6.06	154
6 x 6 x	150 x 150 x	1-1/2	40	8.74	222	14.38	365	6.06	154
6 x 6 x	150 x 150 x	2	50	8.74	222	14.38	365	6.06	154
8 x 8 x	200 x 200 x	3/4	20	11.30	287	15.00	381	7.91	201
8 x 8 x	200 x 200 x	1	25	11.30	287	15.00	381	7.91	201
8 x 8 x	200 x 200 x	1-1/2	40	11.30	287	15.00	381	7.91	201
8 x 8 x	200 x 200 x	2	50	11.30	287	15.00	381	7.91	201

Plug



SIZE		A	
in	mm	in	mm
4	100	5.9	150
6	150	7.0	178
8	200	8.1	206
10	250	9.0	228
12	300	9.8	249

BLUE BRUTE® PIPING SYSTEMS CONT'D

Double Tapped Coupling

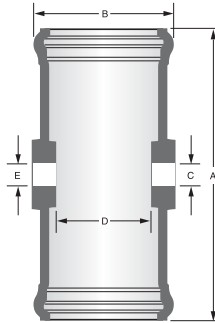

Note: 3/4 inch (20 mm) Taps to 2 inch (50 mm)

Taps: AWWA Thread

SIZE		A		B		C		D		E	
in	mm	in	mm	in	mm	in	mm	in	mm	in	mm
6x ³ / ₄ x ³ / ₄	150x20x20	14.38	365	8.74	222	³ / ₄	20	6.06	154	0.75	20
6x1x ³ / ₄	150x25x20	14.38	365	8.74	222	1	25	6.06	154	0.75	20
6x1x1	150x25x25	14.38	365	8.74	222	1	25	6.06	154	1	25
6x1 ¹ / ₄ x ³ / ₄	150x32x20	14.38	365	8.74	222	1 ¹ / ₄	32	6.06	154	0.75	20
6x1 ¹ / ₄ x1	150x32x25	14.38	365	8.74	222	1 ¹ / ₄	32	6.06	154	1	25
6x1 ¹ / ₂ x ³ / ₄	150x40x20	14.38	365	8.74	222	1 ¹ / ₂	40	6.06	154	0.75	20
6x1 ¹ / ₂ x1	150x40x25	14.38	365	8.74	222	1 ¹ / ₂	40	6.06	154	1	25
6x2x ³ / ₄	150x50x20	14.38	365	8.74	222	2	50	6.06	154	0.75	20
6x2x1	150x50x25	14.38	365	8.74	222	2	50	6.06	154	1	25
8x ³ / ₄ x ³ / ₄	200x20x20	15.00	381	11.30	287	³ / ₄	20	7.91	201	0.75	20
8x1x ³ / ₄	200x25x20	15.00	381	11.30	287	1	25	7.91	201	0.75	20
8x1x1	200x25x25	15.00	381	11.30	287	1	25	7.91	201	1	25
8x1 ¹ / ₄ x ³ / ₄	200x32x20	15.00	381	11.30	287	1 ¹ / ₄	32	7.91	201	0.75	20
8x1 ¹ / ₄ x1	200x32x25	15.00	381	11.30	287	1 ¹ / ₄	32	7.91	201	1	25
8x1 ¹ / ₂ x ³ / ₄	200x40x20	15.00	381	11.30	287	1 ¹ / ₂	40	7.91	201	0.75	20
8x1 ¹ / ₂ x1	200x40x25	15.00	381	11.30	287	1 ¹ / ₂	40	7.91	201	1	25
8x2x ³ / ₄	200x50x20	15.00	381	11.30	287	2	50	7.91	201	0.75	20
8x2x1	200x50x25	15.00	381	11.30	287	2	50	7.91	201	1	25

Tee

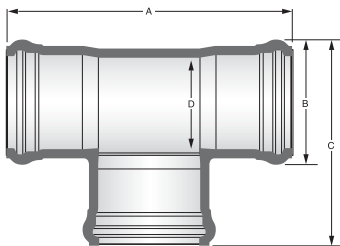

SIZE		A		B		C		D	
in	mm	in	mm	in	mm	in	mm	in	mm
4x4x4	100x100x100	14.04	357	6.27	159	10.15	258	4.88	124
6x6x4	150x150x100	16.99	432	8.88x6.27	226x159	12.43	316	6.93	176
6x6x6	150x150x150	18.92	481	8.88	226	13.90	353	6.93	176
8x8x4	200x200x100	18.55	471	11.37x6.27	289x159	14.68	373	9.13	232
8x8x6	200x200x150	20.48	520	11.37x8.88	289x226	16.14	410	9.13	232
8x8x8	200x200x200	22.46	571	11.37	289	16.91	430	9.13	232

IPEX CENTURION® PIPING SYSTEMS

IPEX Centurion extends the corrosion-free benefits of Blue Brute to larger diameters of pipe and new applications. The versatility and ease of installation of IPEX Centurion is unmatched – shop drawings are eliminated and costly and difficult to install corrosion protection can be eliminated. In addition, unlike HDPE or concrete pressure pipe, every length of IPEX Centurion is tested to double its pressure rating.

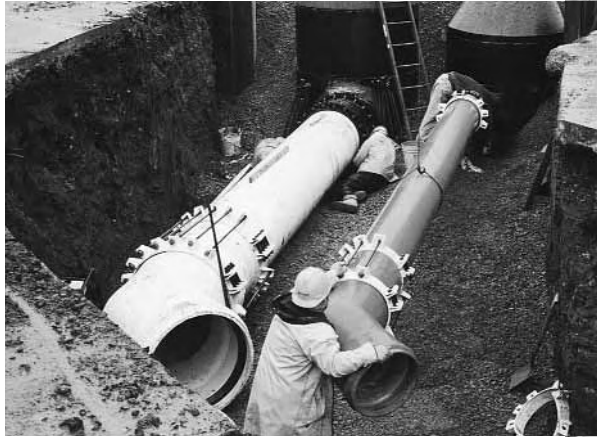

Applications:

Water transmission lines, forcemains.

Irrigation, gravity lines, industrial lines



IPEX CENTURION® PIPING SYSTEMS CONT'D

Pressure Ratings

IPEX Centurion can withstand extremely high short term pressures, in addition to lower levels of long-term pressure. As a result, the AWWA M23 Manual includes both long term pressure ratings (LTR) and short term ratings (STR).

SDR	Short Term Rating STR* (2.5:1 S.F.) (psi)	Long Term Rating LTR* (2:1 S.F.) (psi)
51	100	80
41	130	100
32.5	165	125
26	205	160
25	215	165
18	300	235
14	395	305

Note: Values have been rounded to the nearest 5 psi

Surge Pressures in IPEX Centurion

Transient pressures in pipelines occur as a result of the fluid velocity changing over a relatively short time. The method for approximating a surge pressure is described in section 2, however it should be noted that for most large diameter pipelines, a formal transient analysis should be carried out by a qualified person in order to fully understand the effects of transients in any given system. The method shown in section 2 is certainly appropriate for initial design purposes however.

The table below shows the surge pressure generated assuming an instantaneous stoppage of a flow moving at 0.3 m/s (1 ft/s).

SDR	Surge Pressure (psi)
51	10.8
41	11.4
32.5	12.8
26	14.5
25	14.7
18	17.4
14	19.8



IPEX CENTURION® PIPING SYSTEMS CONT'D

IPEX Centurion for Gravity Applications

With its pressure rated joints and non-corroding construction, IPEX Centurion- is a natural choice for gravity flow lines. When designing any flexible conduit application, the ring deflection should be calculated for the applicable loading conditions. The table below shows the ring deflections for a variety of different SDR configurations based on depth of bury and H2O loading. For more information on how to calculate ring deflections on PVC pipe, please refer to the IPEX Sewer Design Manual.

1. Deflection values shown include effect of H2O live load and dead load.
2. External loading based upon a prism load of soil weight of 120 lbs. per cubic foot (1 900 kg/m3).
3. Bedding classifications correspond to ASTM D2321.
4. The deflection lag factor is 1.0 for a prism load.
5. DR18 deflections have not been shown because they are insignificant in most cases.
6. Recommended maximum deflection is 7.5%.
Contact IPEX for applications where greater deflections are anticipated.
7. n/r - not recommended for H2O live load (ok with dead load)

Standards:

AWWA C905, CSA B137.3, NQ 3624-250, NSF-61

Factory Mutual:

SDR18 is FM approved to 500mm diameter (20")

Underwriter's Laboratories 1218:

SDR18 is listed to 600mm diameter (24")

SDR25 is listed to 750mm diameter (30")



Short Form Specifications

General

Pipe must conform to AWWA C905 and be certified to CSA B137.3 "Rigid Poly (Vinyl Chloride) (PVC) Pipe for Pressure Applications." DR51, 41, 32.5, 25, 18, and 14 pipe must have the following pressure ratings: 80 psi (550 kPa), 100 psi (690 kPa), 125 psi (860 kPa), 165 psi (1 140 kPa), 235 psi (1 620 kPa) and 305 psi (2 100 kPa). For pressure applications, each length of pipe must be hydro-tested at twice the rating and a short-term pressure test must be conducted once per production run. Pipe to be IPEX Centurion or approved equal.

Fabricated Fittings

Fabricated fittings shall be made from segments of AWWA C905 pipe that are butt fused or bonded together and over-wrapped with fiberglass-reinforced polyester. the fittings must always meet the pressure rating of the pipe system.

Table 1 – Percent (%) Deflection for IPEX Centurion Pressure Pipe

ASTM EMBEDMENT MATERIAL CLASSIFICATION	DENSITY (PROCTOR) AASHTO T-99	E' psi (kPa)	DR	HEIGHT OF COVER														
				(ft.) 1 (m)0.3	2 0.6	4 1.2	6 1.8	8 2.4	10 3.0	15 4.6	20 6.1	25 7.6	30 9.1	35 10.7	40 12.2	45 13.7	50 15.2	
Manufactured Granular Angular	CLASS I	90%	3,000 (20 700)	51	n/r	0.5	0.3	0.4	0.4	0.5	0.7	0.9	1.1	1.4	1.6	1.8	2.0	2.3
				41	n/r	0.5	0.3	0.4	0.4	0.4	0.7	0.9	1.1	1.3	1.6	1.8	2.0	2.2
				32.5	0.7	0.5	0.3	0.3	0.4	0.4	0.7	0.9	1.1	1.3	1.5	1.7	2.0	2.2
				25	0.7	0.5	0.3	0.3	0.4	0.4	0.6	0.8	1.0	1.2	1.4	1.6	1.9	2.1
Clean Sand & Gravel	CLASS II	90%	2,000 (13 000)	51	n/r	0.7	0.5	0.5	0.6	0.7	1.0	1.3	1.7	2.0	2.3	2.7	3.0	3.4
				41	n/r	0.7	0.5	0.5	0.6	0.7	1.0	1.3	1.7	2.0	2.3	2.6	3.0	3.3
				32.5	1.0	0.7	0.5	0.5	0.6	1.0	1.3	1.6	1.9	2.2	2.6	2.9	3.2	
				25	1.0	0.7	0.4	0.5	0.5	0.6	0.9	1.2	1.5	1.8	2.1	2.4	2.7	2.9
	CLASS II	80%	1,000 (7 000)	51	n/r	1.5	1.0	1.1	1.1	1.3	2.0	2.6	3.3	4.0	4.6	5.3	5.9	6.6
				41	n/r	1.4	1.0	1.0	1.1	1.3	1.9	2.6	3.2	3.8	4.5	5.1	5.8	6.4
				32.5	2.0	1.3	0.9	1.0	1.0	1.2	1.8	2.4	3.0	3.6	4.2	4.8	5.4	6.0
				25	1.7	1.1	0.8	0.8	0.9	1.0	1.6	2.1	2.6	3.1	3.6	4.2	4.7	5.2
Sand & Gravel with Fines	CLASS III	90%	1,000 (7 000)	51	n/r	1.5	1.0	1.1	1.1	1.3	2.0	2.6	3.3	4.0	4.6	5.3	5.9	6.6
				41	n/r	1.4	1.0	1.0	1.1	1.3	1.9	2.6	3.2	3.8	4.5	5.1	5.8	6.4
				32.5	2.0	1.3	0.9	1.0	1.0	1.2	1.8	2.4	3.0	3.6	4.2	4.8	5.4	6.0
				25	1.7	1.1	0.8	0.8	0.9	1.0	1.6	2.1	2.6	3.1	3.6	4.2	4.7	5.2
	CLASS III	85%	500 (3 500)	51	n/r	n/r	1.9	2.0	2.2	2.6	3.8	5.1	6.4	7.7	8.9	10.2	11.5	12.8
				41	n/r	n/r	1.8	1.9	2.1	2.4	3.6	4.8	6.0	7.2	8.4	9.6	10.8	12.0
				32.5	n/r	2.4	1.6	1.7	1.8	2.1	3.2	4.3	5.3	6.4	7.5	8.5	9.6	10.7
				25	n/r	1.9	1.3	1.3	1.4	1.7	2.5	3.3	4.2	5.0	5.9	6.7	7.5	8.4
Silt & Clay	CLASS IV	85%	400 (2 760)	51	n/r	n/r	2.4	2.5	2.7	3.1	4.7	6.3	7.9	9.4	11.0	12.6	14.1	15.7
				41	n/r	n/r	2.2	2.3	2.5	2.9	4.4	5.8	7.3	8.8	10.2	11.7	13.1	14.6
				32.5	n/r	2.8	1.9	2.0	2.2	2.5	3.8	5.1	6.3	7.6	8.9	10.1	11.4	12.7
				25	n/r	2.1	1.4	1.5	1.6	1.9	2.9	3.8	4.8	5.7	6.7	7.6	8.6	9.5

IPEX CENTURION® PIPING SYSTEMS CONT'D

Dimensions

IPEX Centurion is manufactured with a cast iron outside diameter (CIOD) so it is compatible with much of the existing older infrastructure of iron pipes. In addition, IPEX Centurion can be field cut, which means unexpected changes in the field can be accommodated quickly, without having to wait for new shop drawings.

IPEX Centurion Fittings are manufactured using sections of AWWA C905 pipe, overwrapped with a layer of fibre reinforced plastic (FRP). While IPEX Centurion is compatible with iron fittings, IPEX recommends the use of IPEX Centurion fittings exclusively with IPEX Centurion pipe.

		*PR 80 (DR51)						*PR100 (DR41)						*PR 125 (DR32.5)					
Size		Avg. ID		Min. Wall Thickness		Avg. OD		Avg. ID		Min. Wall Thickness		Avg. OD		Avg. ID		Min. Wall Thickness		Avg. OD	
in	mm	in	mm	in	mm	in	mm	in	mm	in	mm	in	mm	in	mm	in	mm	in	mm
14	350	-	-	-	-	-	-	14.6	369.7	0.37	9.5	15.3	388.6	-	-	-	-	-	-
16	400	-	-	-	-	-	-	16.6	420.4	0.43	10.8	17.4	442.0	-	-	-	-	-	-
18	450	18.7	475.9	0.38	9.7	19.5	495.3	18.5	471.1	0.48	12.1	19.5	495.3	-	-	-	-	-	-
20	500	20.8	527.0	0.42	10.8	21.6	548.6	20.5	521.8	0.53	13.4	21.6	548.6	-	-	-	-	-	-
24	600	24.8	629.6	0.50	12.8	25.8	655.3	24.5	623.3	0.63	16.0	25.8	655.3	24.2	615.0	0.80	20.2	25.8	655.3
30	750	30.7	780.9	0.63	15.9	32.0	812.8	30.4	773.2	0.78	19.8	32.0	812.8	30.0	762.8	0.98	25.0	32.0	812.8
36	900	36.8	934.7	0.75	19.1	38.3	972.8	36.4	925.3	0.93	23.7	38.3	972.8	35.9	912.9	1.18	29.9	38.3	972.8
42	1050	42.6	1082.8	0.87	22.2	44.5	1130.3	42.2	1071.4	1.09	27.5	44.5	1130.3	41.6	1056.6	1.37	34.8	44.5	1130.3
48	1200	48.7	1236.2	1.00	25.3	50.8	1290.3	48.2	1223.0	1.24	31.5	50.8	1290.3	-	-	-	-	-	-

* Pressure rating includes a 2:1 safety factor.

		PR 165 (DR25)						PR 235 (DR18)						PR 305 (DR14)					
Size		Avg. ID		Min. Wall Thickness		Avg. OD		Avg. ID		Min. Wall Thickness		Avg. OD		Avg. ID		Min. Wall Thickness		Avg. OD	
in	mm	in	mm	in	mm	in	mm	in	mm	in	mm	in	mm	in	mm	in	mm	in	mm
14	350	14.1	357.5	0.61	15.5	15.3	388.6	13.6	345.4	0.85	21.6	15.3	388.6	13.1	333.0	1.09	27.8	15.3	388.6
16	400	16.0	406.6	0.70	17.7	17.4	442.0	15.5	392.9	0.97	24.6	17.4	442.0	14.9	378.8	1.24	31.6	17.4	442.0
18	450	17.9	455.7	0.78	19.8	19.5	495.3	17.3	440.3	1.08	27.5	19.5	495.3	-	-	-	-	-	-
20	500	19.9	504.7	0.86	21.9	21.6	548.6	19.2	487.6	1.20	30.5	21.6	548.6	-	-	-	-	-	-
24	600	23.7	602.9	1.03	26.2	25.8	655.3	22.9	582.5	1.43	36.4	25.8	655.3	-	-	-	-	-	-
30	750	29.4	747.8	1.28	32.5	32.0	812.8	-	-	-	-	-	-	-	-	-	-	-	-
36	900	35.2	895.0	1.53	38.9	38.3	972.8	-	-	-	-	-	-	-	-	-	-	-	-
42	1050	-	-	-	-	-	-	-	-	-	-	-	-	-	-	-	-	-	-
48	1200	-	-	-	-	-	-	-	-	-	-	-	-	-	-	-	-	-	-

CYCLETOUGH® PIPING SYSTEMS

CycleTough piping systems are specially designed for applications where pressures are expected to cycle up and down repeatedly, such as sewage forcemains, irrigation systems and other applications. One of the most important things to remember with CycleTough systems is that the fittings are made with PVC compound that has the same hydrostatic design basis (HDB) as the pipe. Most competing PVC fittings are made with compound having a significantly lower HDB, thus potentially compromising the system performance. Always specify a complete system of pipes and fittings from the same manufacturer to ensure matching fittings.



Applications:

Forcemains, irrigation.

Rural water supply, water distribution and transmission.

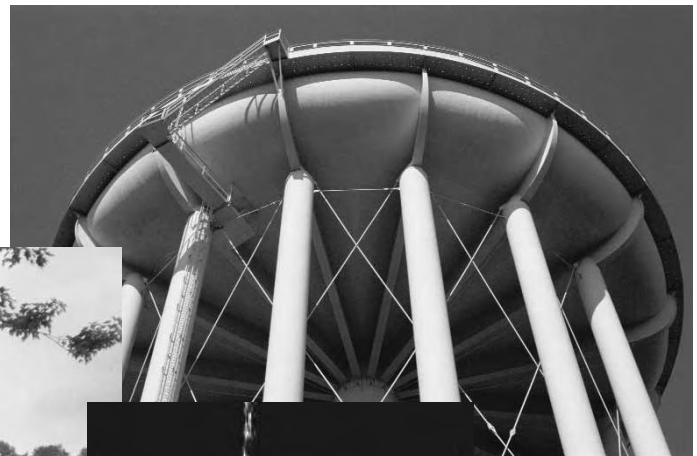

CYCLETOUGH® PIPING SYSTEMS CONT'D

Pressure Ratings

CycleTough pipe is available in long term various pressure ratings, from 100 to 200 psi:

SDR	Short Term Rating (STR)	Long Term Rating (LTR)
41	130	100
32.5	165	125
26	205	160
21	255	200

For more information on how these ratings are calculated, please refer to section 3.

Standards

CycleTough Pipe

Certified to **CSA B137.3** – Rigid Poly (Vinyl Chloride) (PVC) Pipe for Pressure Applications

ASTM D2241 – Poly (Vinyl Chloride) (PVC) Plastic Pipe (SDR-PR) PVC

NSF-PW – NSF approved for potable water

Conforms to **AWWA C905** – except for the hydrostatic test of each pipe length



CycleTough Fittings

Certified to **CSA B137.3**

Various **ASTM** Standards

NSF-61



Short Form Specifications

IPSOD PVC Pipe shall be manufactured from PVC compound with an ASTM Cell class of 12454B. PVC Compound will have a minimum long term hydrostatic design basis of 4000 psi and a short term HDB of 6400 psi. Pipe shall be certified to CSA B137.3.

Injection molded PVC fittings shall be made from PVC compound with a minimum long term HDB of 4000 psi.

Fabricated fittings shall be made from sections of pipe certified to CSA B137.3, and shall also be certified to CSA B137.3.

All pipes and fittings shall be NSF-61 approved and color coded white.



CYCLETOUGH® PIPING SYSTEMS CONT'D

Dimensions

CycleTough pipe and fittings are manufactured with an Iron Pipe Size outside diameter (IPSOD). This outside diameter

configuration is consistent with that used for Schedule piping (sch. 40 and 80) as well as steel pipe sizes.

Size		Series 100 (SDR41)						Series 125 (SDR32.5)					
		Avg. ID		Min. Wall Thickness		Avg. OD		Avg. ID		Min. Wall Thickness		Avg. OD	
in	mm	in	mm	in	mm	in	mm	in	mm	in	mm	in	mm
3	75	-	-	-	-	-	-	3.271	83.09	.108	2.74	3.50	88.9
4	100	4.278	108.41	.109	2.78	4.50	114.3	4.208	106.88	.138	3.50	4.50	114.3
6	150	6.282	159.57	.162	4.12	6.63	168.3	6.194	157.32	.204	5.18	6.63	168.3
8	200	8.180	207.77	.209	5.32	8.62	219.1	8.063	204.80	.265	6.72	8.62	219.1
10	250	10.194	258.93	.262	6.66	10.75	273.1	10.049	255.24	.331	8.40	10.75	273.1
12	300	12.093	307.15	.311	7.90	12.75	323.9	11.921	302.78	.392	9.96	12.75	323.9
14	350	13.277	337.24	.341	8.66	14.00	355.6	13.090	332.49	.429	10.90	14.00	355.6
16	400	15.174	385.41	.390	9.90	16.00	406.4	14.957	379.90	.492	12.50	16.00	406.4
18	450	17.074	433.67	.437	11.10	18.00	457.2	16.823	427.31	.555	14.10	18.00	457.2
20	500	18.985	481.71	.488	12.40	20.00	508.0	18.698	474.93	.614	15.60	20.00	508.0
24	600	22.756	578.01	.587	14.90	24.00	609.6	22.431	569.74	.740	18.80	24.00	609.6

Size		Series 160 (SDR26)						Series 200 (SDR21)					
		Avg. ID		Min. Wall Thickness		Avg. OD		Avg. ID		Min. Wall Thickness		Avg. OD	
in	mm	in	mm	in	mm	in	mm	in	mm	in	mm	in	mm
1-1/2	40	1.731	43.97	.080	2.02	1.90	48.3	1.709	43.42	.090	2.28	1.90	48.3
2	50	2.184	55.47	.091	2.30	2.38	60.4	2.137	54.29	.113	2.86	2.38	60.4
2-1/2	65	2.642	67.11	.109	2.78	2.87	73.0	2.584	65.62	.137	3.48	2.87	73.0
3	75	3.215	81.65	.135	3.42	3.50	88.9	3.146	79.91	.167	4.24	3.50	88.9
4	100	4.134	105.01	.172	4.38	4.50	114.3	4.046	102.77	.214	5.44	4.50	114.3
6	150	6.085	154.56	.255	6.48	6.63	168.3	5.957	151.30	.316	8.02	6.63	168.3
8	200	7.921	201.20	.331	8.42	8.62	219.1	7.756	197.00	.409	10.40	8.62	219.1
10	250	9.874	250.79	.413	10.50	10.75	273.1	9.665	245.49	.512	13.00	10.75	273.1
12	300	11.717	297.61	.488	12.40	12.75	323.9	11.467	291.25	.606	15.40	12.75	323.9
14	350	12.857	326.56	.539	13.70	14.00	355.6	12.589	319.77	.665	16.90	14.00	355.6
16	400	14.698	373.33	.614	15.60	16.00	406.4	14.381	365.27	.764	19.40	16.00	406.4
18	450	16.531	419.89	.693	17.60	18.00	457.2	16.180	410.98	.858	21.80	18.00	457.2
20	500	18.364	466.45	.772	19.60	20.00	508.0	17.980	456.70	.953	24.20	20.00	508.0
24	600	22.039	559.78	.925	23.50	24.00	609.6	21.580	548.12	1.142	29.00	24.00	609.6

CYCLETOUGH® PIPING SYSTEMS CONT'D

90° Elbow G x G

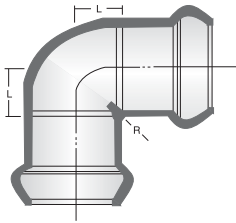

SIZE		L		R	
in	mm	in	mm	in	mm
2	50	1.18	29.5	0.75	18.8
2-1/2	65	1.80	45.0	1.00	25.0
3	75	2.00	50.0	1.00	25.0
4	100	2.20	55.0	1.00	25.0
6	150	2.80	70.0	1.25	31.3
8	200	4.87	121.8	1.50	37.5

45° Elbow G x G

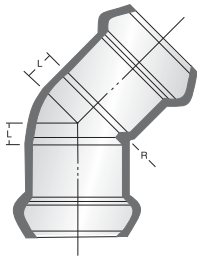

SIZE		L		R	
in	mm	in	mm	in	mm
2	50	0.60	15.0	0.75	18.8
2-1/2	65	1.80	45.0	1.00	25.0
3	75	1.12	28.0	1.00	25.0
4	100	1.10	27.5	1.00	25.0
6	150	1.60	40.0	1.25	31.3
8	200	2.40	60.0	1.50	37.5

Tee G x G x G

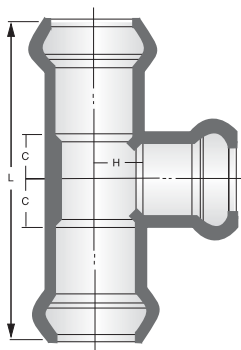

SIZE		C		H		L	
in	mm	in	mm	in	mm	in	mm
2	50	1.30	32.5	1.10	27.5	7.60	190.0
2-1/2	65	1.67	41.8	1.63	40.8	9.50	237.5
3	75	1.99	49.8	1.99	49.8	10.80	270.0
4	100	2.57	64.3	2.65	66.3	12.50	312.5
6	150	3.76	94.0	3.77	94.3	14.90	372.5
8	200	4.91	122.8	4.91	122.8	21.65	541.3

PRODUCT INFORMATION

CYCLETOUGH® PIPING SYSTEMS CONT'D

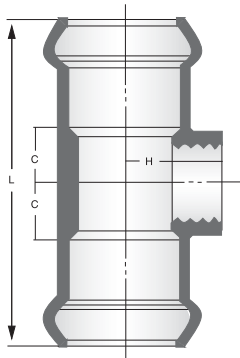
Tap Service Tee - NPT Outlet

SIZE		C		H		L	
in	mm	in	mm	in	mm	in	mm
2 x 1/2	50 x 15	1.40	35.0	2.15	53.8	7.10	177.5
2 x 3/4	50 x 20	1.40	35.0	2.15	53.8	7.10	177.5
2 x 1	50 x 25	1.40	35.0	2.15	53.8	7.10	177.5
2 x 1-1/4	50 x 32	1.40	35.0	2.15	53.8	7.10	177.5
2 x 1-1/2	50 x 40	1.40	35.0	2.15	53.8	7.10	177.5
2-1/2 x 1/2	65 x 15	1.45	36.3	2.50	62.5	7.90	197.5
2-1/2 x 3/4	65 x 20	1.45	36.3	2.50	62.5	7.90	197.5
2-1/2 x 1	65 x 25	1.45	36.3	2.50	62.5	7.90	197.5
2-1/2 x 1-1/4	65 x 32	1.45	36.3	2.50	62.5	7.90	197.5
2-1/2 x 1-1/2	65 x 40	1.45	36.3	2.50	62.5	7.90	197.5
2-1/2 x 2	65 x 50	1.45	36.3	2.50	62.5	7.90	197.5
3 x 1/2	75 x 15	1.50	37.5	2.70	67.5	9.75	243.8
3 x 3/4	75 x 20	1.50	37.5	2.70	67.5	9.75	243.8
3 x 1	75 x 25	1.50	37.5	2.70	67.5	9.75	243.8
3 x 1-1/4	75 x 32	1.50	37.5	2.70	67.5	9.75	243.8
3 x 1-1/2	75 x 40	1.50	37.5	2.70	67.5	9.75	243.8
3 x 2	75 x 50	1.50	37.5	2.70	67.5	9.75	243.8
4 x 1/2	100 x 15	1.56	39.0	3.10	77.5	10.17	254.3
4 x 3/4	100 x 20	1.56	39.0	3.10	77.5	10.17	254.3
4 x 1	100 x 25	1.56	39.0	3.10	77.5	10.17	254.3
4 x 1-1/4	100 x 32	1.56	39.0	3.10	77.5	10.17	254.3
4 x 1-1/2	100 x 40	1.56	39.0	3.10	77.5	10.17	254.3
4 x 2	100 x 50	1.56	39.0	3.10	77.5	10.17	254.3
6 x 1/2	150 x 15	1.80	45.0	3.96	99.0	13.00	325.0
6 x 3/4	150 x 20	1.80	45.0	3.96	99.0	13.00	325.0
6 x 1	150 x 25	1.80	45.0	3.96	99.0	13.00	325.0
6 x 1-1/4	150 x 32	1.80	45.0	3.96	99.0	13.00	325.0
6 x 1-1/2	150 x 40	1.80	45.0	3.96	99.0	13.00	325.0
6 x 2	150 x 50	1.80	45.0	3.96	99.0	13.00	325.0

CYCLETOUGH® PIPING SYSTEMS CONT'D

Reducing Tee - G x G x G

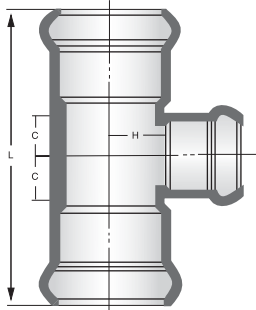

SIZE		C		H		L	
in	mm	in	mm	in	mm	in	mm
2 x 1-1/2	50 x 40	1.30	32.5	1.10	27.5	7.60	190.0
2-1/2 x 2	65 x 50	1.67	41.8	1.63	40.8	9.50	237.5
3 x 1-1/2	75 x 40	1.85	46.3	1.60	40.0	10.80	270.0
3 x 2	75 x 50	1.85	46.3	1.60	40.0	10.80	270.0
3 x 2-1/2	75 x 65	1.90	47.5	1.60	40.0	10.80	270.0
4 x 2	100 x 50	1.90	47.5	2.00	50.0	11.30	282.5
4 x 2-1/2	100 x 65	1.90	47.5	2.00	50.0	11.30	282.5
4 x 3	100 x 75	1.90	47.5	2.00	50.0	11.30	282.5
6 x 2	150 x 50	2.40	60.0	2.80	70.0	14.90	372.5
6 x 2-1/2	150 x 65	2.40	60.0	2.80	70.0	14.90	372.5
6 x 3	150 x 75	2.40	60.0	2.80	70.0	14.90	372.5
6 x 4	150 x 100	2.40	60.0	2.80	70.0	14.90	372.5
8 x 2	200 x 50	3.85	96.3	4.87	121.8	19.50	487.5
8 x 3	200 x 75	3.85	96.3	4.87	121.8	19.50	487.5
8 x 4	200 x 100	3.85	96.3	4.88	122.0	19.50	487.5
8 x 6	200 x 150	3.85	96.3	4.88	122.0	19.50	487.5

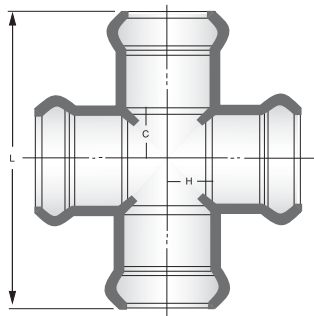

Cross G x G x G x G

SIZE		C		H		L	
in	mm	in	mm	in	mm	in	mm
4	100	4.00	100.0	4.00	100.0	12.50	312.5
6	150	4.50	112.5	4.50	112.5	16.00	400.0

Stop Coupling G x G

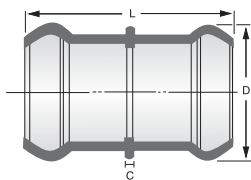

SIZE		L		D	
in	mm	in	mm	in	mm
2	50	5.00	125.0	3.35	83.8
2-1/2	65	7.14	178.5	4.15	103.8
3	75	7.00	175.0	5.00	125.0
4	100	7.40	185.0	6.13	153.3
6	150	10.00	250.0	8.73	218.3
8	200	12.30	307.5	10.62	265.5

CYCLETOUGH® PIPING SYSTEMS CONT'D

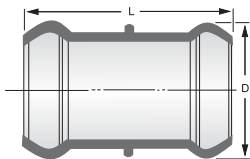

Repair Coupling G x G

SIZE		L		D	
in	mm	in	mm	in	mm
2	50	7.20	180.0	3.35	83.8
2-1/2	65	7.00	175.0	4.15	103.8
3	75	7.00	175.0	5.00	125.0
4	100	7.40	185.0	6.13	153.3
6	150	10.00	250.0	8.73	218.3
8	200	12.30	307.5	10.62	265.5

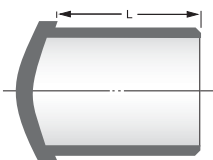

Permanent Plug Spigot

SIZE		L	
in	mm	in	mm
1-1/2	40	2.50	62.5
2	50	2.50	62.5
2-1/2	65	3.50	87.5
3	75	3.50	87.5
4	100	3.75	93.8
6	150	4.50	112.5

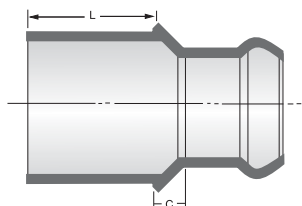

Increaser Bushing - G x Sp

SIZE		L		C	
in	mm	in	mm	in	mm
1-1/2 x 2	40 x 50	2.40	60.0	0.20	5.0
2 x 2-1/2	50 x 65	2.40	60.0	0.20	5.0
2 x 3	50 x 75	3.40	85.0	0.55	13.8
2-1/2 x 3	65 x 75	3.40	85.0	0.38	9.5
2 x 4	50 x 100	3.00	75.0	0.40	10.0
2-1/2 x 4	65 x 100	3.00	75.0	0.40	10.0
3 x 4	75 x 100	3.00	75.0	0.40	10.0
2 x 6	50 x 150	4.30	107.5	0.50	12.5
2-1/2 x 6	65 x 150	4.30	107.5	0.50	12.5
3 x 6	75 x 150	4.30	107.5	0.50	12.5
4 x 6	100 x 150	4.30	107.5	0.50	12.5
4 x 8	100 x 200	5.10	127.5	0.60	15.0
6 x 8	150 x 200	5.10	127.5	0.60	15.0

CYCLETOUGH® PIPING SYSTEMS CONT'D

Adapter - Flange x Gasket Bell

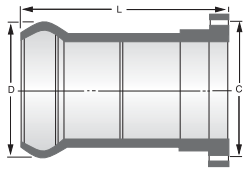

SIZE		C		D		L	
in	mm	in	mm	in	mm	in	mm
1-1/2	40	3.85	96.3	5.00	125.0	4.25	106.3
2	50	4.75	118.8	6.00	150.0	4.75	118.8
2-1/2	65	5.50	137.5	7.00	175.0	5.75	143.8
3	75	6.00	150.0	7.50	187.5	6.50	162.5
4	100	7.48	187.0	9.02	225.5	10.52	263.0
6	150	9.55	238.8	10.97	274.3	13.48	337.0
8	200	11.75	293.8	13.50	337.5	12.00	300.0

Spigot Adapter G x Sp

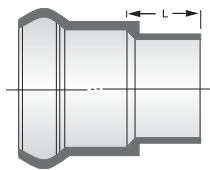

SIZE		L	
in	mm	in	mm
1-1/2	40	1.50	37.5
2	50	1.80	45.0
2-1/2	65	2.00	50.0
3	75	2.10	52.5
4	100	2.30	57.5
6	150	3.10	77.5

Male Adapter G x Male Pipe Thread

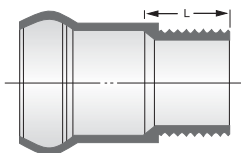

SIZE		L	
in	mm	in	mm
1-1/2	40	1.05	26.3
2	50	1.20	30.0
2-1/2	65	1.55	38.8
3	75	2.10	52.5
4	100	2.25	56.3
6	150	2.50	62.5

CYCLETOUGH® PIPING SYSTEMS CONT'D

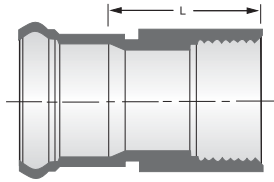

Adapter Bell x Female IPT

SIZE		L	
in	mm	in	mm
1-1/2	40	2.60	65.0
2	50	3.00	75.0
2-1/2	65	3.80	95.0
3	75	4.10	102.5
4	100	4.40	110.0
6	150	5.40	135.0

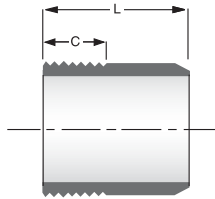

Adapter - PE (Plain End) x Male Pipe Thread

SIZE		L		C	
in	mm	in	mm	in	mm
3	75	4.30	107.5	2.00	50.0
4	100	4.40	110.0	2.25	56.3
6	150	5.90	147.5	2.50	62.5

TERRABRUTE® RESTRAINED JOINT PIPE

TerraBrute is a modified AWWA C900 pipe that has been specifically designed for use with trenchless installation techniques like horizontal directional drilling (HDD) and pipe bursting. Using an innovative system of rings and pins, TerraBrute can withstand higher pull forces than any other plastic piping system, while simultaneously being able to bend and flex in a borehole.

In addition to trenchless installations, TerraBrute's versatile joint is perfect for above ground installations like bridge crossings where there may be significant temperature extremes. Where other piping systems require costly and maintenance intensive expansion joints, the wide groove in each TerraBrute joint allows expansion and contraction of each pipe.

Another key attribute of the TerraBrute joint is that it allows pipe rotation without damage. This can be an issue in seismic zones where piping systems are subjected to a wide variety of soil induced stresses during earthquake events.



PRODUCT INFORMATION

Applications:

HDD, pipe bursting, bridge crossings, seismic zones, casing installations and steep slopes.



TERRABRUTE® RESTRAINED JOINT PIPE CONT'D

Pulling Forces

The magnitude of pulling force exerted on a pipe string during pulled in place type installation methods depends on a number of factors, including:

- The length of the pull
- The diameter of the pipe
- The type of soil
- Selection of drilling fluid.

TerraBrute has been designed to withstand extremely high pulling forces in order to perform under even the toughest conditions. While most projects will use only a fraction of the ultimate strength of TerraBrute, the extra strength acts as an “insurance policy” against unexpected conditions.

TerraBrute’s ultimate pull strength has been verified by laboratory tests, and can be calculated using a semi-empirical design method derived by researchers at the University of Western Ontario (UWO). The following table shows both the ultimate pulling capacity of the product (no safety factor) as well as the recommended maximum pulling capacity (2:1 safety factor)

Nominal Size		Recommended Pulling Limit		Ultimate Pulling Capacity (Straight Pull)	
mm	Inches	kN	lbs	kN	Lbs.
100	4	50	11200	100	22400
150	6	110	24700	220	49500
200	8	115	25800	230	51700
250	10	187	42100	375	84300
300	12	275	61800	550	123600

Bending Forces

PVC pipe is much stiffer than the pipe material most commonly used for HDD and other trenchless methods – HDPE pipe. This has led some designers to wonder if PVC is too rigid to be used for these types of applications. In fact, stiffness and flexibility are two different properties. It is possible for a material to be very stiff and strong but still quite flexible. TerraBrute is flexible enough for virtually any HDD or pipe bursting operation, and can be installed to a much tighter radius than other PVC products. In fact, since TerraBrute is more flexible than the drilling rods, there is virtually no way to “over bend” the pipe. In addition, the high stiffness of the material means that there is very little deformation of the pipe string during pulling operations. As a result, appurtenances such as services and hydrant leads can be installed immediately after pulling operations are completed.

One of the most important characteristics of the TerraBrute joint is that it allows significant joint deflection. A significant portion of the bending is taken up by the joints, which reduces the amount of stress exerted on the pipe ball from bending. This allows TerraBrute to be installed to a much tighter radius than other PVC products.

The table below shows how much TerraBrute can be deflected at the joint during pullback operations, as well as how much the pipe barrel itself can be bent. Most projects will involve both pipe bending and joint deflection, often at the same time.

Nominal Size		Allowable Joint Deflection	Allowable Pipe Bending	Minimum Allowable Radius	
mm	in	(degrees)	(degrees)	meters	Feet
100	4	8.5	5.7	11.3	37.1
150	6	8.5	4	13.1	43
200	8	7.5	3	15.9	52.2
250	10	5	2.5	22.8	74.8
300	12	5	2.1	24.1	79.1



TERRABRUTE® RESTRAINED JOINT PIPE CONT'D

Joint Assembly

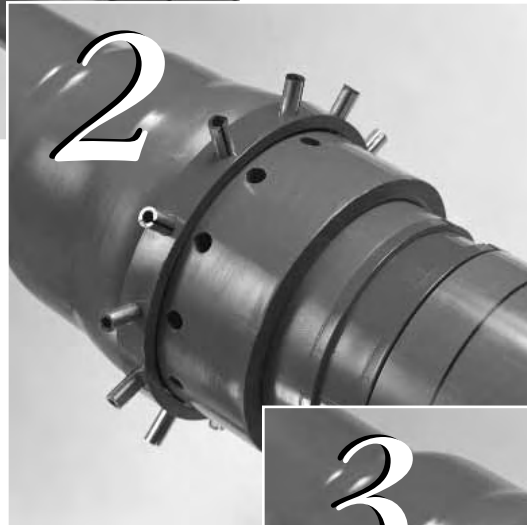
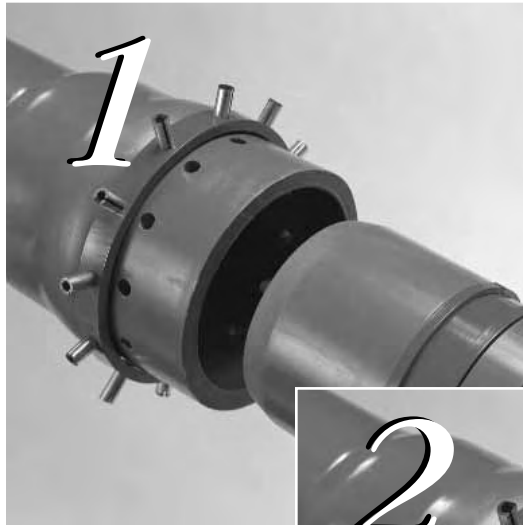

PRODUCT INFORMATION

TERRABRUTE® RESTRAINED JOINT PIPE CONT'D

External Pressures

Drilling fluids are used under many different soil conditions both to keep the borehole open and to remove the spoil from drilling and reaming operations. This drilling fluid is pressurized, and as a result, it is important that a pipe joint be able to withstand these external pressures without leaking fluid into the pipe string. IPEX has tested fully deflected joints to well over 100 psi external pressure with zero leakage.

Standards

AWWA C900

TerraBrute is made with pipe conforming to AWWA C900, however once the pipe is grooved on the spigot end its dimensions do not match those published in the C900 standard. Because of this small dimensional difference the pipe, once grooved, does not strictly conform to the C900 standard. It is important to note however, that TerraBrute is subjected to the same testing program as IPEX's Blue Brute (C900) pipe.

CSA B137.3

TerraBrute is made from stock certified to **CSA B137.3**.

NQ 3624-250

Factory Mutual and Underwriter's Laboratories

TerraBrute is made from starting stock that is **Factory Mutual, ULC** and **ULI** Approved



Short Form Specifications

PVC Pipe used for horizontal directional drilling (HDD) or other trenchless installation methods shall be manufactured with a cast iron outside diameter (CIOD) and shall be made with starting stock meeting the requirements of AWWA C900 for 100mm - 300mm (4" - 12") diameters. Starting stock will also be certified to CSA B137.3, must be Factory Mutual approved, and listed by ULC and ULI.

The maximum allowable pulling force shall be the ultimate tensile capacity of the piping system divided by a safety factor of 2, as shown in the table below.

Nominal Size		Maximum Allowable Pulling Force	
mm	Inches	kN	Lbs.
100	4	50	11200
150	6	110	24700
200	8	115	25800
250	10	187	42100
300	12	275	61800

PVC pipe must be manufactured with an integral bell, and must have removable gaskets to allow the use of oil-resistant (nitrile) gaskets in contaminated soils.

Dimensions

TerraBrute is virtually identical to Blue Brute dimensionally. It has a slightly shorter laying length, 6.0 meters (19'8") as a result of the slightly extended bell, as well as a groove cut into the spigot end of the pipe. One key dimension that must be remembered when planning pre-ream operations is the absolute maximum outside diameter of the pipe. The table below shows the maximum outside diameter of each size.

Nominal Size		Maximum Outside Diameter (Outside Ring)	
mm	Inches	mm	Inches
100	4	160	6.3
150	6	230	9.1
200	8	290	11.4
250	10	350	14.2
300	12	415	16.3

Due to the extended bell configuration, TerraBrute has slightly shorter laying length than standard Blue Brute pipe:

Nominal Size		Laying Lengths	
mm	Inches	m	Feet/Inches
100	4	6.04	19' 10"
150	6	6.03	19' 9"
200	8	6.01	19' 9"
250	10	6.01	19' 9"
300	12	6.01	19' 9"

Q-LINE® WATER SERVICE TUBING

Q-Line is a composite pipe made with a layer of aluminum sealed between two layers of a special thermoplastic designed for use as water service tubing. The result is a pipe with all the advantages of both materials, and none of the weaknesses. It has the strength of metal service tubing and will never corrode as the metal is sealed in plastic. It rolls out flat like a metal pipe, but it is lightweight like a plastic pipe.



Applications:

Water service lines, reclaimed water lines (purple pipe available)

Non-Conductor

Roughly 370 serious electric shock incidents occur in the U.S. water utility industry every year¹. While the AWWA has opposed the practice of grounding to the water system for over 80 years, it is still routinely done, despite the availability of grounding rods and plates. Since Q-Line is a non-conductor, it eliminates the risk of electric shock from stray currents. Specifying Q-line helps to eliminate the risk to municipal workers.

Effective Permeation Barrier

Chemical permeation is a real issue with small diameter service tubing made of PE. Q-Line's aluminum core is an effective barrier and has been tested against the most aggressive contaminants such as termiticides.

Zero Scrap Value

The high scrap value of copper pipe has resulted in significant pilferage problems on job sites across North America. This has resulted in storage problems as all copper pipe must be properly secured each day.



¹ Duranceau, Schiff, Bell. "Electrical Grounding, Pipe Integrity and Shock Hazard", Journal of the AWWA, July 1998, pp. 40-51

Q-LINE® WATER SERVICE TUBING CONT'D

Pressure Ratings

Q-Line is rated at 200 psi working pressure at 23°C (73°F). In addition, Q-Line is rated at 100 psi at 82°C (180°F). Since most water services operate at between 40 and 70 psi, even a back up of hot water from the building into the water service will not compromise Q-Line.

Flow Rates

With larger inside diameters than CTS polyethylene piping and a super-smooth interior wall that does not permit build-up of calcium or other minerals, Q-Line offers the best flow rates in the industry. The typical C value for designing with copper is C=90-100. And unlike metallic pipe, with a Hazen-Williams flow coefficient of C=150, Q-Line will not corrode or allow build-up inside the tube which can increase friction losses.

Table 2 – Q-Line Flow Rates

Flow Rate (U.S. gpm)	Head Loss (psi/100 ft)		Velocity (fps)		Flow Rate (l/s)	Head Loss (kPa/100m)		Velocity (m/s)	
	3/4"	1"	3/4"	1"		20mm	25mm	20mm	25mm
1.0	.1	0.0	.7	0.4	0.1	7.2	2.4	0.3	0.2
2.0	.5	0.2	1.3	0.8	0.2	26.1	8.8	0.6	0.4
3.0	1.0	0.4	2.0	1.3	0.3	55.3	18.7	1.0	0.6
4.0	1.8	0.6	2.6	1.7	0.4	94.2	31.8	1.3	0.8
5.0	2.7	0.9	3.3	2.1	0.5	142.4	48.1	1.6	1.0
6.0	3.8	1.3	4.0	2.5	0.6	199.6	97.4	1.9	1.2
7.0	5.0	1.7	4.6	3.0	0.7	265.5	89.7	2.2	1.4
8.0	6.4	2.2	5.3	3.4	0.8	340.0	114.8	2.6	1.6
9.0	8.0	2.7	5.9	3.8	0.9	422.9	142.8	2.9	1.8
10.0	9.7	3.3	6.6	4.2	1.0	514.0	173.6	3.2	2.0
11.0	11.6	3.9	7.2	4.6	1.1	613.3	207.1	3.5	2.2
12.0	13.6	4.6	7.9	5.0	1.2	720.5	243.3	3.8	2.5
13.0	15.7	5.3	8.5	5.5	1.3	835.7	282.2	4.1	2.7
14.0	18.0	6.1	9.2	5.9	1.4	958.6	323.7	4.5	2.9
15.0	20.5	6.9	9.9	6.3	1.5	1089.2	367.8	4.8	3.1
16.0	23.1	7.8	10.5	6.7	1.6	1227.5	414.5	5.1	3.3
17.0	25.8	8.7	11.2	7.1	1.7	1373.4	463.8	5.4	3.5
18.0	28.7	9.7	11.8	7.6	1.8	1526.8	515.5	5.7	3.7
19.0	31.7	10.7	12.5	8.0	1.9	1687.5	569.8	6.1	3.9
20.0	34.9	11.8	13.2	8.4	2.0	855.7	616.6	6.4	4.1
21.0	38.2	12.9	13.8	8.9					
22.0	41.7	14.1	14.5	9.2					
23.0	45.2	15.3	15.1	9.7					
24.0	-	16.5	-	10.1					
25.0	-	17.8	-	10.5					
26.0	-	19.2	-	11.0					
27.0	-	20.6	-	11.4					
28.0	-	22.0	-	11.8					
29.0	-	23.5	-	12.2					
30.0	-	25.0	-	12.7					

Q-LINE® WATER SERVICE TUBING CONT'D

Codes and Standards

Q-Line water service tubing is manufactured to AWWA C903, ASTM F1282 and CSA B137.9, and meets NSF-PW potable water requirements as well as requirements of the following national codes.



- National Plumbing code of Canada
- Uniform Plumbing Code
- International Plumbing Code
- International Residential Code
- National Standard Plumbing Code
- SBCCI Standard Plumbing Code

Short Form Specifications

Water service tubing shall be composite PE-AL-PE tubing manufactured in accordance with the requirements of AWWA C903 and certified to CSA B137.9 and ASTM F1282. It shall have a long term pressure rating of 1380kPa at 23°C (200 psi at 73°F) and 690kPa at 82°C (100 psi at 180°F). The pipe shall be third-party tested and certified to comply with NSF-PW potable water and NSF CL-TD chlorine resistance requirements. the service tubing shall be color coded light blue as manufactured by IPEX under the trade name “Q-Line” or approved equal.

Fittings for composite PE-AL-PE tubing shall be brass water service fittings conforming to AWWA C800.

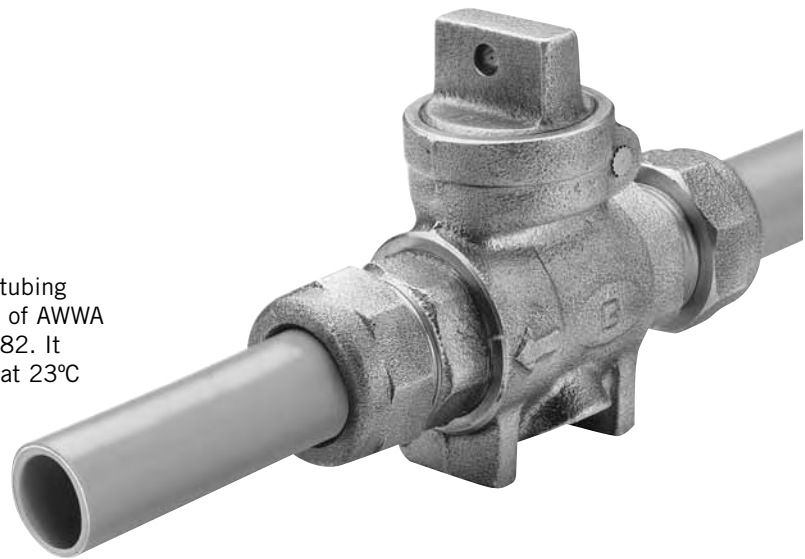

Dimensions

Q-Line has unique inside and outside diameters that are different both from copper and conventional PE service tubing. Easily installed adapters that allow Q-line to be used with standard brass fittings are widely available. Unlike PE pipe, Q-line does not require a stiffening insert to be used.

Nominal Size		Avg. ID		Min. Wall Thickness		Avg. OD		Weight		Volume		Min. Bending Radius	
in	mm	in	mm	in	mm	in	mm	lbs/100ft	kg/100m	U.S. gal/ft	l/m	in	mm
3/4	20	.79	20	.10	2.5	.98	25	12.4	18.4	.025	.314	5.0	125
1	25	.98	25	.14	3.5	1.26	32	21.0	31.2	.040	.500	6.3	160

STANDARDS FOR PVC PRESSURE SYSTEMS

Standards and Certification

There are two main classes of standards governing PVC piping systems, those which define products that are certified by a third party and those which define products that are non-policed. While non-policed standards can be very useful in a specification, the standards that are certified by a third party offer the customer an additional level of quality assurance. Third party certification means that an independent organization has scrutinized the manufacturing process and QA/QC procedures for the products in question, and has verified that they meet the minimum requirements for approval. Compliance with a non-policed standard requires the customer to take the manufacturer at his word that his product conforms to the standard. Most manufacturers perform accurate in house testing and are honest and up front, and if when they state that their products meet a certain standard, you can be quite certain that they do. There is no question however, that certification by a third party provides a much higher degree of assurance that the products in question in fact meets the applicable standard and that it will perform as stated.

Third Party Certified Standards

Canadian Standards Association (CSA)

CSA B137.0

CSA B137.1

CSA B137.2

CSA B137.3

CSA B137.9

CSA Staff visit all IPEX plants producing certified product several times each year. In addition to witnessing manufacturing and QA/QC procedures, CSA staff also inspect records, and select product samples for independent testing. The CSA standards refer to a wide variety of external standards (such as ASTM standards) for such things as testing methods. As a result, certifying the product to a CSA standard often has the effect of indirectly certifying the product to other standards as well.

Factory Mutual and Underwriter's Laboratories

FM 1612

UL and ULI Listed to Standard 1285

These third party certified standards are often required whenever the piping system is going to be used as a fire protection line. Insurance regulations often dictate the required standard, however to be safe, most designers simply specify all three CSA, UL and FM organizations. The certification methods are similar to those used by the CSA – plant inspections and independent material testing.

National Sanitation Foundation (NSF)

NSF-61

NSF-14

NSF 61 certification is required for all products that will carry potable water. NSF 14 standards do not deal with product performance, including but with the effect of the product on potable water. NSF certification means that the compound used to make the pipe or fitting has no adverse effect on the water it carries. NSF certifies the material, not the pipe or fitting itself.

Accreditation of Standards Labs and Organizations

While the standards discussed above are normally certified by a third party, that third party can sometimes be a separate organization. For example, Intertek Warnock-Hersey is a laboratory accredited by the Standards Council of Canada, and as a result, it is capable of certifying products to standards. It is common for Intertek Warnock-Hersey to certify a product to a CSA standard, and NSF also has this capability.

Only NSF, FM and UL can certify to their own standards however.

Non-Certified Standards

American Water Works Association

AWWA C900

AWWA C903

AWWA C905

AWWA C907

C900, 905 and 907 all deal with PVC pressure pipe and fittings, while C903 is a new standard for composite service piping. Q-line is covered by this standard. AWWA standards are most commonly used when specifying piping systems for water transmission or distribution.

ASTM Standards (Various standards)

ASTM Standards are referenced by all the above standards. They cover everything from manufacturing to testing and installation, which is why there are so many different ASTM standards associated with our products. While they are “non-policed”, the fact that many ASTM standards are included in policed standards means that indirectly, they are third party certified standards.

Design and Installation Standards

AWWA M23 – PVC Pipe – Design and Installation

The M23 manual sets out all of the guidelines needed to properly design and install a PVC water system. In addition, it carefully defines the difference between distribution mains and transmission mains, and explains how to properly design for surges. It also includes worked examples of the various design concepts. It is an excellent reference for anyone involved with water system design or installation.

SECTION 2: PROPERTIES OF PVC PRESSURE PIPE AND PRESSURE SYSTEM DESIGN

INTRODUCTION

Properly designed and installed PVC piping systems will last virtually forever. Recent research has unearthed PVC systems that were installed in the 1930's that exhibit virtually no reduction in serviceability. This section focuses on the physical properties of PVC pipes and fittings, as well as how to approach some of the conditions likely to be encountered during a project.

Various design issues will also be addressed including;

- The hydrostatic design basis (HDB) of PVC pipe
- Calculating pressure ratings
- Hydraulics and headloss calculations
- Restraint design
- Installation in contaminated soils
- Surge pressures in PVC pipe
- Air entrapment and proper location of air release valves
- Thermal effects
- Design for cyclic fatigue

MATERIAL PROPERTIES OF PVC

Design Life

Designers should use a minimum 100 year design life when carrying out lifecycle costing calculations for PVC systems. This is backed up both by research and real world installations.

Current Research

PVC pressure pipes have been in service for over 70 years in Europe². Samples of 70 year old pipe have been excavated and have exhibited no reduction in serviceability. PVC pipe's installed history in North America is approaching 50 years, with a similar record for flawless service. The single most destructive force attacking our municipal water and sewer infrastructure is corrosion. By using materials that are immune to electrolytic corrosion or chemical attack, designers eliminate the single most common problem associated with buried infrastructure.

Research dealing with the longevity of PVC pipe in various conditions is on-going, however there have been a number of notable research papers presented over the years, including:

- AWWA Research Foundation – *“Quantifying Future Rehabilitation and Replacement Needs of Watermains”, 1998*

This study used a highly specialized computer model to estimate the life of various materials based on past performance. In the one North American City studied with a significant amount of PVC pipe installed, PVC was rated at a minimum 100 years while concrete and ductile iron were rated at 85 and 60 years respectively.

- “PVC Pipe Study – *Performance of PVC Water Main*

Pipe installed in the City of Edmonton between 1977 and 1994”.

A comprehensive study of PVC pipe used in the City's water distribution system rated its service life at a minimum of 88 years with minimal maintenance.

Case Studies from Europe and North America including:

- Dallas, Texas – A PVC sewer pipe installed in 1973 was excavated and subjected to each of the tests outlined in ASTM D3034. The results show that the excavated pipe still met all the standards applicable to new pipe
- Denmark – A PVC Sewer pipe installed in 1963 was excavated and testing results show that the pipe has the same material properties as newly produced pipe. Most of the pipes installed were directly into native soil without bedding, and have performed acceptably for over 40 years.

These research papers are available upon request from your IPEX marketing representative at marketing@ipexinc.com or visit the IPEX website at www.ipexinc.com.



² Hulsmann, Nowack, “70 Years of Experience with PVC Pipes” Conference Paper, Plastic Pipes XII, Milan, April 2004

Design Strength

While Blue Brute pipes are casually referred to as PVC pipes, in reality they are made of a special PVC compound designed specifically for use in piping systems. The Hydrostatic design basis (HDB) of a PVC compound is the minimum stress that the material is able to withstand over a given time. The HDB's of IPEX compounds are established through both short-term and long-term testing (up to 100,000 hours sustained pressure). By plotting the results on a logarithmic scale, the 50 or 100 year design stresses can be easily extrapolated. The diagram below shows a typical life line for a PVC compound.

Figure 1 – Stress Regression Line - 12454

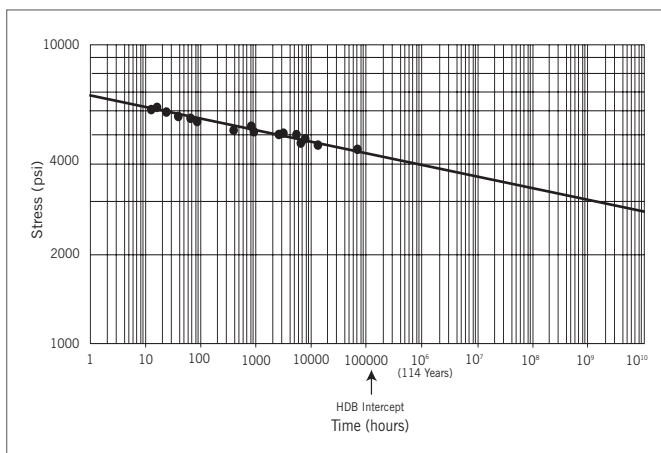

As can be seen from the diagram, PVC compounds have:

- **High Short Term Strength**

While all IPEX PVC pressure pipes have a long-term hydrostatic design basis of 4000 psi, in the short term their strength is much higher – 6400 psi. This means that the pipe can easily withstand extremely high short term pressures, such as those generated by transient surges. For example, although an SDR18 pipe is rated at 235 psi, it routinely withstands well over 1000 psi during quick burst tests.

- **Dependable Long-Term Strength**

At normal operational stress levels, the lifespan of the material is virtually unlimited. Because of the large reserves of strength, even stresses that build to levels above the normal safety factors can be accommodated.

Summary of Material Properties

All PVC pressure pipes are made of a proprietary PVC compound formulated specifically for pressure pipe applications.

Table 3 – Summary of Properties

Material Property	
Long-term Hydrostatic Design Basis (HDB)	26.6 MPa (4000 psi)
Short-Term Hydrostatic Design Basis (STHDB)	44.1 Mpa (6400 psi)
ASTM Cell Class (ASTM F1784)	12454B
Young's Modulus	266 Mpa (400,000 psi)
Poisson's Ratio	0.38

Chemical Permeation and Installation of PVC Pipe in Contaminated Soils

There is a misconception among some designers that PVC pipe is unsuitable for installation in areas that contain soils contaminated by organic compounds. This misconception stems from the fact that there have been rare occurrences where small diameter plastic service lines have been permeated by organic chemicals. This is not an issue with larger diameter PVC pipes because:

1. The vast majority of documented permeation incidents occurred with thin wall service pipes made of lower density materials such as polybutylene or polyethylene³. These small diameter pipes are indeed unsuitable for contaminated soils. Only service pipe with a built in permeation barrier (such as Q-Line) should be used in these cases.
2. PVC pipe has an effective permeation time of many centuries, even at extremely high levels of environmental contamination. This has been conclusively proven through research⁴.
3. The high density and non-porous finish of PVC pipe makes it very difficult for permeation to occur. Samples of IPEX pressure pipe we partially filled with gasoline and sealed for seven years. When the inside surface of the pipe was examined microscopically, no evidence of permeation was found⁵.

Gaskets are the weak link when installing gasketed piping systems in contaminated soils, the most important consideration is the gasket material, regardless of the piping material. To ensure safe, long-term operation of the pipeline, oil-resistant (nitrile) gaskets should always be specified.

Lastly, many designers consult chemical resistance guides for information about installation in contaminated soils. These guides are usually inappropriate for this application as they typically deal with a 100% concentration of the material in question. You should consult with your IPEX technical representative before making any decisions with respect to suitability for a particular application.

³ Jenkins, Thompson, "Review of Water Industry Plastic Pipe Practices", AWWA Research Foundation, 1987

⁴ Berens, A.R., "Prediction of Chemical Permeation through PVC Pipe", Journal of the AWWA, November 1985

⁵ Hoogensen Metallurgical Engineering Ltd., "Examination of Submitted PVC Pipe Section", Report to IPEX, December 1998

Thermal Effects and UV Resistance

PVC pipe can become discolored when exposed to direct sunlight for a long period of time. This discoloration affects only the surface of the material (to a depth of 0.001 and 0.003 inches), and does not appreciably affect the performance of the pipe. A slight reduction in the impact strength of the pipe occurs, while the tensile strength and the modulus of elasticity are unaffected. If gasketed PVC pressure piping will be used in an exposed location, painting the surface of the pipe with a latex based paint, or covering it with an opaque barrier will eliminate the effects of U.V. exposure.

The vast majority of gasketed pressure piping is installed underground, eliminating the issue of UV exposure.

PVC is a thermoplastic, which means its mechanical properties change with temperature. The pressure rating for PVC pipe (and most other thermoplastic piping materials) is calculated at 23°C (73°F). Above that temperature, the tensile strength of the material decreases, and the pressure rating must be de-rated by the factors shown in the table below. The maximum recommended service temperature for PVC pressure pipe is 140°F.

Table 4 – Temperature Effects on PVC Pressure Pipe

°C	°F	Multiply the pressure rating by these factors
32	90	0.75
38	100	0.62
43	110	0.50
49	120	0.40
54	130	0.30
60	140	0.22

Expansion and Contraction

While buried applications seldom involve significant temperature variations, applications such as bridge crossings or casing installations can have temperature variations. When considering the use of unrestrained joints or TerraBrute joints, expansion and contraction should be calculated per length of pipe. If the joints are restrained using conventional restrainers, or a solvent cemented joint is used, expansion and contraction should be calculated using the full length of restrained pipe.

Material	Coefficient in/in/°F	Expansion in/100ft/10°F	Coefficient mm/mm/°C	Expansion mm/10m/10°C
PVC	3.0 X 10 ⁻⁵	0.36	5.4 X 10 ⁻⁵	5.4
HDPE	1.2 X 10 ⁻⁴	1.44	1.4 X 10 ⁻⁴	21.6
Ductile Iron	6.2 X 10 ⁻⁶	0.07	1.1 X 10 ⁻⁵	1.1
Concrete	5.5 X 10 ⁻⁶	0.07	9.9 X 10 ⁻⁶	1.0
Steel	6.5 X 10 ⁻⁶	0.08	1.2 X 10 ⁻⁵	1.2

DESIGN CALCULATIONS

How to Calculate a Pressure Class or Pressure Rating

The ISO Equation for thermoplastics makes calculating required dimension ratios and pressure ratings very simple.

While it is referred to as the ISO Equation, it was actually developed in 1852, for use with all sorts of pressure vessels, and has been used ever since. The derivation is simple:

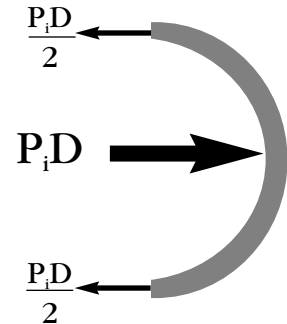

Referring to the Figure, we can see that the force in the pipe wall is:

$$\text{Force} = \left(\frac{P_i D}{2} \right)$$

Therefore, the maximum stress in the pipe wall is:

$$\sigma_{\max} = \frac{P_i \bar{D}}{2t}, \text{ where } \bar{D} = \text{the average diameter of the pipe}$$

$$\bar{D} = D_o - t \therefore \sigma_{\max} = \frac{P_i(D_o - t)}{2t}$$

$$\text{But since } DR = \frac{D_o}{t}, \text{ then } \sigma_{\max} = \frac{P_i(DR - 1)}{2}$$

The conservative design procedure of PVC pipe requires that a safety factor be applied to the hydrostatic design basis in order to arrive at a *design stress* – *S*. This design stress then becomes the maximum allowable stress in the material. Note that the short and long term strengths of the material are different, therefore the short-term design stress and the long-term design stress will be different.

The safety factor is usually set between 2 and 2.5 depending on the application, and the standard governing the design.

$$S = \frac{\sigma_{\max}}{SF}$$

Substituting this expression for design stress, we get

$$S = \frac{P(DR - 1)}{2} \therefore P = \frac{2S}{(DR - 1)}$$

This form of the equation allows the pressure capabilities of a given dimension ratio to be quickly and easily calculated. To see a worked example of how to calculate pressure ratings, please refer to section 3.

Calculating a Pressure Rating

There are two ratings on every PVC pipe – a long term pressure rating (LTR) which is used for evaluating working pressure capacity, and a short term pressure rating (STR) designed for evaluating surge and transient pressure capability.

To calculate an STR, simply apply the ISO equation using the short term HDB.

Recall that:

$$S = \frac{\sigma_{max}}{SF}$$

For short term stresses, AWWA M23 sets the safety factor (SF) = 2.5. Using the short term HDB gives:

$$S_{str} = \frac{6400}{2.5} = 2560 \text{ psi}$$

Therefore for DR41 pipe, the STR is given by

$$STR = \frac{2(2560)}{(41 - 1)} = 128 \text{ psi}$$

For long term stresses, the safety factor is set at 2.0:

$$S_{tr} = \frac{4000}{2} = 2000 \text{ psi}$$

Applying the ISO Equation:

$$LTR = \frac{2(2000)}{(41 - 1)} = 100 \text{ psi}$$

The table below shows both the LTR and the STR for various thicknesses of PVC pipe

SDR	Short Term Rating STR* (2.5:1 S.F.) (psi)	Long Term Rating LTR* (2:1 S.F.) (psi)
51	100	80
41	130	100
32.5	165	125
26	205	160
25	215	165
18	300	235
14	395	305

*Values have been rounded to the nearest 5 psi

Calculating a Pressure Class as per AWWA C900 (100mm – 300mm CIOD Pipe)

The C900 standard refers to Pressure Classes, which are different from pressure ratings. A pressure class differs from a pressure rating in a number of ways:

It includes a design safety factor (F) of 2.5 as opposed to 2.0

It includes a “surge allowance” equivalent to the pressure generated by a theoretical instantaneous stoppage of 0.6 m/s (2 ft/s) in the pipeline

The short term pressure class is not used as a 2 ft/s (0.6 m/s) surge is already included

$$PC = \left[\frac{(2 \times HDB)}{(DR - 1)} \times \frac{1}{F} \right] - P_s$$

$$PC = \left[\frac{2(4000)}{(DR - 1)} \times \frac{1}{2.5} \right] - P_s$$

Table 5 – AWWA C900 Pressure Classes (100mm-300mm (4"-12") pipe)

Dimension Ratio	Ps = 0.6 m/s (2ft/s) (psi)	Pressure Class
25	30	100
18	35	150
14	40	200

Calculating Friction Headloss in PVC Piping Systems

One of the advantages in using PVC pipe is that its smooth inside finish dramatically reduces friction headloss when compared to other materials. As a result, pumping costs are lower and flows are higher when considering the same nominal diameter between materials.

The Hazen-Williams equation is one of the most commonly used methods for calculating friction headloss in a pipeline. It allows the friction headloss to be easily calculated for any piping system using flow coefficients that reflect the roughness of the piping material. Research has established that the Hazen-Williams flow coefficient for PVC pipe can vary between 155 to 165 for both new and previously used PVC pipe⁶. Therefore, a conservative coefficient of 150 is appropriate for all design situations. This value is also recommended by the AWWA M23 Design Manual.

$$V = 1.318Cr^{0.63}S^{0.54} \quad \text{in USCS Units}$$

$$V = 0.8492Cr^{0.63}S^{0.54} \quad \text{in SI Units}$$

Where:

- V = average pipe velocity, ft/s (m/s)
- C = Hazen-Williams Friction factor (150 for PVC Pipe)
- R = Hydraulic radius (D/4 for a full pipe), ft (m)
- S = Hydraulic gradient or frictional head loss per unit length of pipe, ft/ft, (m/m)

Comparing Headloss Among Various Piping Materials

For any given nominal diameter of pipe, there are two factors which will largely dictate the headloss per unit length:

1. Internal diameter – It is the internal diameter of the pipe that should be used for hydraulic calculations, not the nominal diameter. A larger internal diameter promotes a higher fluid flow and therefore a lower headloss.
2. Internal friction coefficient – While internal diameter is important, the influence of the pipeline’s internal finish should not be neglected. While PVC and other plastics can sustain a smooth inside surface indefinitely, other materials tend to become rougher as a result of corrosion by-products forming over the long term. As a result, older iron pipes have been shown to have friction factors less than 100.

While experimental data has shown that the “C” factor can be as high as 155-165 for both new and used PVC pipe, AWWA M23 Manual recommends a “C” factor of 150 for PVC⁷.

Table 6 – Hazen-Williams “C”-Factors⁸

Material	“C” Factor
Plastic (PVC & HDPE)	150
Iron (new)	130
Iron (20 yrs old)	100

The “C” factors obviously have a significant effect on flow rates. Comparing various materials it can be seen that PVC pipe has a much lower headloss at any given flow than other common piping materials.

Class 52 iron pipe has a slightly higher inside diameter than DR18 PVC, but its low long-term C factor of 100 or less results in poor flow characteristics.

SDR9 HDPE has a high C factor of 150, however it has a much thicker pipe wall and thus has a much lower inside diameter than PVC SDR18.

Figure 2 – Pipe Material

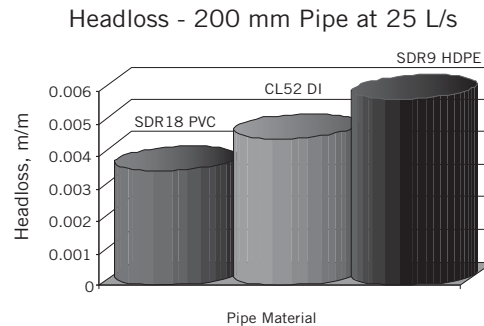

Calculating Surge Pressures

Surge pressures (water hammer) are generated in a piping system whenever the fluid flowing in that system changes velocity. These changes in velocity can be caused by many things, including:

- The operation of valves and pumps
- Entrapped air being expelled
- Changes in demand

There are two main types of surge pressures - transient surges that occur as the system moves from one steady state condition to another (ie: the closing of a single valve), and cyclic surges, that occur as part of the normal operation of some types of pipelines. A good example of this is a sewage forcemain, where a pump is activated each time the level in a wet well reaches a certain point.

The magnitude of pressure surges is dependent upon a number of things, including the type of fluid being pumped, the magnitude of the velocity change, and also the type of pipe material. Rigid piping materials typically generate much higher surge pressures than flexible systems, which are able to absorb much more of the shock generated by a surge. In addition, the high short term strength of PVC allows it to have a much higher safety factor against short term pressures than other piping materials .

The calculation of transient effects in a large piping system (regardless of the piping material) is a complicated procedure requiring considerable expertise. Fortunately, there are many engineering firms that are highly qualified to undertake this type of analysis. IPEX has worked closely with some of these experts, and we would be happy to refer interested designers to them. We highly recommend that detailed transient analysis be carried out of all systems, particularly large diameter systems.

While a detailed analysis can be beneficial, it is possible to calculate the magnitude of individual surges in a pipeline using the elastic wave theory of surge analysis. The magnitude of the surge pressure caused by a rapidly closing valve, for example, is related to the rate of change of the flow, while the rate of travel of the pressure wave is related to the speed of sound in the fluid (modified by the piping material).

⁷ AWWA Manual M23, 2nd Edition – PVC Pipe – Design and Installation, 2002, American Water Works Association
⁸ “Pump Handbook – Third Edition” – Karassik, Messina, Cooper & Heald, pp.8.36

Calculating Wave Velocity

$$a = \frac{4,660}{\sqrt{1 + k/E (DR - 2)}}$$

Where:

- A = Wave velocity, ft/s
- K = Bulk fluid modulus (300,000 psi for water)
- E = Modulus of Elasticity for the pipe (400,000 psi for PVC)

Once the wave speed has been calculated, the maximum pressure surge can be calculated using the equation:

$$P = a(\Delta V)$$

Where:

- A = wavespeed (ft/s)
- ΔA = maximum velocity change (ft/s)
- g = acceleration due to gravity (32.2 ft/s²)
- P = maximum pressure surge (psi)

Applying the equations to all SDR's of PVC pipe, assuming a 1 ft/s (0.3 m/s) stoppage, gives the results in the table below:

SDR	Surge Pressure (psi)
51	10.8
41	11.4
32.5	12.8
26	14.5
25	14.7
18	17.4
14	19.8

Vacuum Pressures

While pipe joints are tested to -10.8 psi to meet CSA Standards, IPEX has simulated negative pressures far in excess of full vacuum (-14.7 psi). By applying external pressures in excess of 100 psi. This proves conclusively that IPEX pipe joints can easily withstand full vacuum pressures.

Air Entrapment in Pipelines

Air in pipelines can cause significant difficulties in any pipeline system, and should be avoided wherever possible. This can be accomplished by careful design of the pump or gravity inlet, employing proper filling and testing procedures, laying the pipe to grade wherever possible and by properly siting and sizing air release valves.

Some of the problems caused by air entrapment include:

1. Air pockets can reduce the amount of cross sectional area available for fluid flow in at some points in the pipeline. This can result in higher headloss and fluctuations in flow rates caused by air movement
2. Flow fluctuations can cause surge pressures in the pipeline
3. Release or venting of the air can cause extremely high surge pressures.

Sources of Air in Pipelines

The most common air sources are:

- Entrapment of air during filling operations
- Entrapment at the pump or gravity inlet
- Release of dissolved air from the fluid in the pipeline
- Air intake from air release valves

Problems Associated with Air Entrapment

The key problem with air entrapment is that at some point the air may be vented in an uncontrolled way. As an air pocket travels along a pipeline, it may reach an area where it can be vented. This could be at an air release valve (good) or perhaps at a gasketed joint (bad). The gasketing systems in most pipelines are designed to work with water, not air. While in most cases the gasket will hold back a high pressure air pocket, at some point the gasket may be blown out of the joint, causing a rapid release of air. Since the air can be vented extremely quickly, the air pocket collapses at an extremely high rate. The water surges toward the orifice created by the blown gasket, but cannot be expelled at the same velocity as the air due to its much higher density. The result is a rapid deceleration of the flow and a huge transient shock wave – sometimes at a magnitude that can cause pipe failure.

Air Release Valves

Air release valves are designed to exhaust air under various different pressure conditions in the pipeline, while restricting the flow of liquid. Air release valves are different than Air/Vacuum release valves in that Air/Vacuum release valves have a much larger orifice and are designed to exhaust or intake very large volumes of air, such as during the filling or draining process. The orifice size for an air release valve is generally between $\frac{1}{16}$ " and $\frac{1}{4}$ " diameter, while air/vacuum release valves can be between 1" and 8".

A third type of valve combines the two functions, and is called a combination air/vacuum release valve. It contains both a large and a small orifice, the larger being open during filling and draining operations, and the smaller being open continuously to exhaust any air that might collect during normal operation of a pipeline.

Automatic air release valves with a riser diameter to main pipe ratio, d/D , in the order of 0.01 should be used when untrained personnel fill or test the pipeline. Air release valves in this size range tend to limit the passage of air and allow time for the water to slow down before reaching the vent.

Hydrants are not useful for the venting of air from pipelines. The reason is that hydrant leads typically are located at the 3 o'clock or 9 o'clock position on a pipeline. Air vents must be located at high points (ie at 12 o'clock) to be effective.

Pipeline Testing and Air Entrapment

The initial filling and testing of a pipeline is one of the most critical events in the lifetime of a pipeline system. The reason is that the potential for air entrapment is highest during this period. As a result, Design Engineers should include details and procedures covering filling and testing in their project specifications:

1. Pipelines should be installed at a grade which results in a minimum of high points. Abrupt transitions and sharp peaks should be avoided.
2. Automatic air and vacuum release valves should be properly sized and installed at all high points or other areas where air could be expected to accumulate
3. The average water velocity when filling the pipeline should not exceed 1 ft/s (0.3 m/s)
4. All air should be purged from the pipeline before checking for leaks or performing pressure or acceptance tests on the system
5. If a large quantity of water is needed to increase the pressure during testing, then entrapped air or a leak is possible. Testing should be discontinued until the source of the problem is identified

Nominal Size		Max Filling Rate	
In	mm	gpm	L/s
4	100	40	2.5
8	200	157	9.9
10	250	245	15.5
12	300	353	22.3
14	350	480	30
16	400	627	39
18	450	793	50
20	500	979	61
24	600	1410	89
30	750	2203	139
36	900	3173	200
42	1050	4318	272
48	1200	5640	355

Further References:

Perhaps the most easily accessible work on the subject of air entrapment in pipelines was a film produced in the late 1960's at Colorado State University. It was commissioned by a major pipe manufacturer and clearly shows the effect of air entrapment in pipelines and the importance of properly sizing and situating air release valves. Contact your IPEX technical rep. for a copy on CD.

Cyclic Fatigue in PVC Pipes

Fatigue is a well known phenomenon that can affect many different materials. Only when a piping system is subjected to extreme cyclic loading conditions does fatigue in PVC pipe become a design factor. Fortunately, there has been a great deal of research done on this topic, and some recent research completed by Dr. A. Moser at Utah State University has contributed greatly to the understanding of this phenomenon.

Dr. Moser has determined that the number of cycles to failure (C) of PVC pipe is a function of the average stress in the pipe walls, as well as the amplitude of the cycles. This builds on previous work done by H.W. Vinson that based the cycles to failure only on the maximum stress in the material.

While cyclic loading is possible in many different applications, it is typically encountered in sewage forcemain and irrigation applications (most water distribution mains or transmission mains have relatively constant pressures). Any

application that has pumps starting up and shutting down at regular intervals (ie more than a couple of times per day) should be analyzed using Dr. Moser's method.

The following graph shows how the average stress and the amplitude are related to the number of cycles to failure

A worked example of a cyclic design for a sewage forcemain can be found in section 3.

Further Reading:

Vinson, H.W.: "Response of PVC Pipe to Large, Repetitive Pressure Surges" Proceedings of the International Conference on Underground Plastic Pipe (March 1981)

Moser, Folkman, Jeffrey: "Long-Term Cyclic Testing of 6 inch PVC Pipe" Utah State University, (March 2003)

Figure 3 – Resulting Cyclic-Failure Curves for PVC

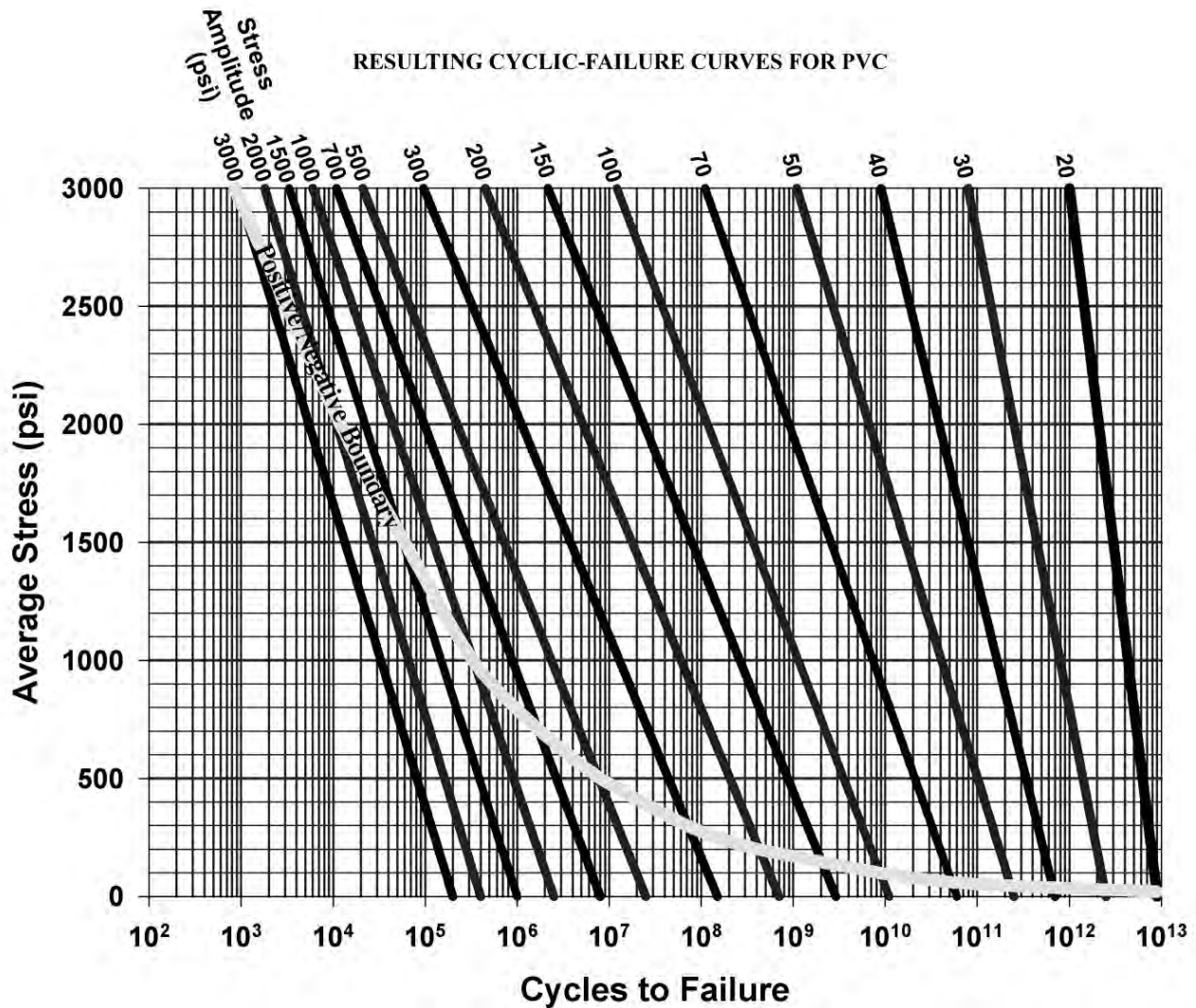

Thrust Restraint in Gasketed Piping Systems

Resisting Thrust at Fittings and Valves

At many locations in a pressurized pipeline, an imbalance in hydrostatic forces may occur as a result of the pipeline configuration. These unbalanced forces are called thrust forces. Thrust forces can occur at any point in a piping system where the directional or cross-sectional area of the waterway changes. Pipeline installers must balance these forces by means of thrust blocks or mechanical restraint. Three areas that require restraint are described below.

- **at valves**

All valves must be anchored. This includes valves installed in a chamber or in line with the pipe, whether it is operated frequently or only once a year.

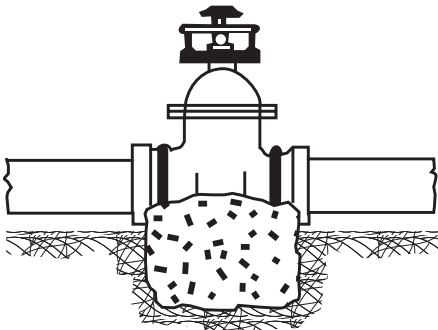

Install anchor rods around the valve body or through the mounting lugs and embed the rods in a concrete pour beneath the valve. Valves installed in chambers must also be anchored in this fashion. The critical time for restraint of valves is during opening or closing.

- **at changes in direction (Vertical or Horizontal)**

Fittings such as elbows, tees, or dead ends, must be restrained since they involve a significant directional change for the fluid.

- **at reductions in size**

The thrust component at reductions in size will depend on the amount of the reduction, and must be adequately restrained.

At each point in the line where thrust forces will develop, pour a concrete block between the fitting and undisturbed native soil at the side of the trench. Use plywood sheets to form the block and control the pour so that the area of contact with the undisturbed trench will provide the necessary support.

Bearing Strength of Undisturbed Soils

Organic Material (such as Peat, etc.)0 lb/ft ²
Soft Clay500 lb/ft ²
Sand	1000 lb/ft ²
Sand and Gravel	1500 lb/ft ²
Sand & Gravel with Clay2000 lb/ft ²
Sand & Gravel Cemented with Clay4000 lb/ft ²
Hard Pan5000 lb/ft ²

These soil bearing capacities are approximate and conservative. For greater design precision IPEX recommends that soil bearing tests be carried out by a competent soils engineer.

The recommended bearing area to be established by the concrete pour may be given by the engineer. The area (ft.²) may also be calculated by determining the total thrust generated at the fitting. Simply divide the bearing strength of the soil into the thrust developed (lbs force), as found in the accompanying table. The result is the area of the soil required to resist the thrust (A). The area calculated will be for the area of concrete up against the trench wall (i.e. the back side of the block).



$$\text{area } A = \frac{\text{Thrust Force}}{\text{Bearing Strength of Soil}}$$

Table 7 – Thrust Developed per 100 psi Pressure (lbs. force)

Pipe Diameter in	mm	Valves & Dend Ends, Tees	90° Bends	45° Bends	22½° Bends	11¼° Bends
4	100	1810	2560	1390	635	320
6	150	3740	5290	2860	1370	690
8	200	6430	9100	4920	2320	1170
10	250	9680	13680	7410	3610	1820
12	300	13690	19350	10470	5080	2550
14	350	18380	25990	14100	6100	3080
16	400	23780	33630	18280	7960	4020
18	450	29860	42230	22970	10060	5080
20	500	36640	51820	28180	12440	6280
24	600	52280	73930	40200	17940	9060
30	750	80425	113737	61557	31500	15800
36	900	115200	162929	88181	45000	22600
42	1050	155500	219950	119000	60700	30500
48	1200	202700	286700	155200	79000	39800

Note: Pre-cast thrust blocks should not be placed directly against PVC fittings.

Resisting Thrust in Very Poor Soils

Where the pipeline passes through soils having little or no bearing strength, thrust forces may be restrained by the encasement of the fitting in concrete and the extension of this pour to form a monolith having sufficient inertia to resist the thrusts. It may also be possible to loop tie rods around the fitting and anchor the tie rods into an upstream concrete pour across the trench in more stable soils. Mechanical thrust restraints may also be used in these cases.

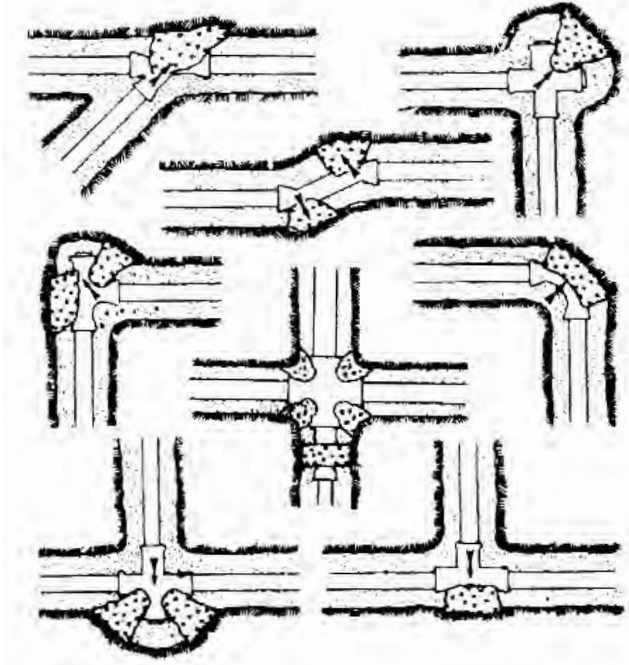

Typical thrust block locations. Trim the trench bearing area using hand tools to be sure of undisturbed soil.

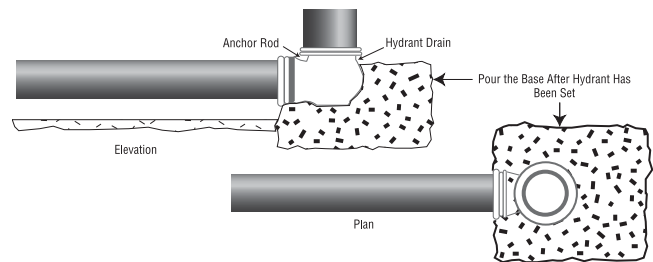

This type of hydrant foundation acts as a thrust-block, as an anchorage against frost heave and eliminates washouts from waste-water drain.

Resisting Vertical Thrust

Where the pipeline will change direction downwards to pass under a creek bed or roadway, etc., upward thrust will be developed at the fitting. Anchor the fitting as though it were a valve, and ensure that the concrete base is keyed into undisturbed soil.

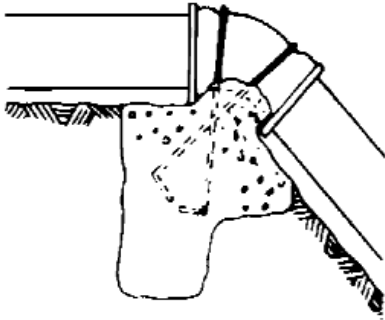

Straps should be 2 inches (50 mm) wide or greater.

Holding Pipe to Steep Slopes

Normal bedding practices for pipelines installed up a hill will be sufficient to prevent backsliding and decoupling. When the height of cover is less than 6 feet (1.8 m), and the soil conditions are marginal, and where the slope is greater than 20° (36% slope), a special anchoring method may be desirable. One recommended procedure is to lay the pipe with the bells facing uphill and pour a concrete block behind the bells and keyed into the undisturbed trench sidewalls. Usually every third length of pipe will need to be anchored in this fashion to achieve a stable condition. The use of solvent welded joints for short sections of the pipeline may also be considered on steep slopes.

Mechanical Thrust Restraints

Several mechanical thrust restraint devices are available which clamp to the wall of the pipe and tie back to a mating collar on the fitting or the pipe bell. The use of these devices may provide the entire thrust restraint necessary at the fitting, in sizes up to 48 inches (1200 mm). The use of several thrust restraints to tie together two or three lengths of pipe on either side of the fitting may be desirable to enlist the clamping effect of the backfill around the pipe barrel. IPEX recommends that the thrust restraint device conforms to the requirements of ASTM F1674-96.

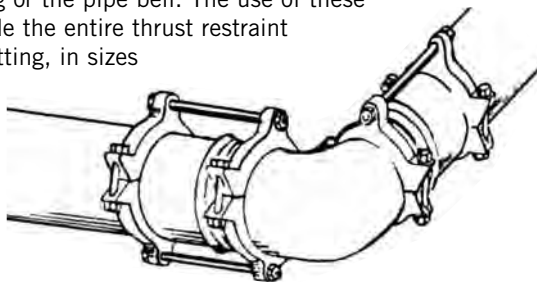

When a thrust restraint device is used the maximum pressure in the pipeline (usually the test pressure) must not exceed the pressure rating of the device.

Assembly, Installation and testing of PVC Pressure Pipe Systems

Detailed information on how to install IPEX pressure pipes and fittings can be found in IPEX's Installation Guide for PVC Pressure Pipe and Fittings. This guide contains complete information on:

- Receiving and handling pipe shipments
- Trench Preparation
- Lowering Pipe into the trench
- Assembling joints
- Curvature of the pipeline, and assembling to valves and appurtenances
- Machining and chamfering the pipe
- Tapping, flanges and sleeves
- Outside diameter considerations
- Backfilling and installing bedding
- Pressure testing the pipeline
- Installing the pipeline through a casing
- Lubricant usage tables.

The Guide is available from your IPEX rep. or visit our technical library at www.ipexinc.com.



SECTION 3 – DESIGN EXAMPLES

HYDRAULIC AND CYCLIC DESIGN EXAMPLE

Sewage Forcemain Design Example (SI Version)

Select the appropriate pipe size and pressure rating for a sewage forcemain with the following characteristics:

Peak Flow = 450 L/s (7130 GPM) Elevation Change (static head): 30 meters (100 feet)

Length: 3000 meters (9850 feet)

Average pump cycles per day: 36

System peak pressure during controlled pump operations: 480 kPa (70 psi)

Minimum pressure during controlled pump operations: 207 kPa (30 psi)

Minimum design life – 50 years

Step 1 – Select an initial nominal pipe size and pressure rating

A maximum velocity of 1.5 m/s (5 ft/s) is typical in forcemain design. This velocity ensures self cleansing of the line.

$$Q = vA \therefore A = \frac{Q}{v}$$

Where,

A = required pipe cross sectional area, m²

V = fluid velocity, m/s

Q = Flow, m³/s

$$A = \frac{0.450 \text{ m}^3/\text{s}}{1.5 \text{ m/s}} = 0.3 \text{ m}^2$$

Required diameter:

$$a = \frac{\pi D^2}{4} \therefore D = \sqrt{\frac{4a}{\pi}} = \sqrt{\frac{4(0.3)}{\pi}} = 0.618 \text{ m} = 618 \text{ mm}$$
 is the required diameter

Static pressure is 298 kPa (43 psi), therefore select 600mm (24") nominal diameter SDR51 (long term pressure rating 80 psi) for initial calculations.

600mm SDR51 Inside Diameter = 630 mm (24.8").

Note: The purpose of these initial calculations is to select a nominal pipe size and pressure rating, so the required diameter numbers do not have to match. It is more important to select the proper pipe that corresponds with the initial system static head. This will give a basis for further calculations of dynamic head and surge pressures in the next steps

Step 2 – Calculate dynamic head (friction and minor losses) and total system head

In this step the Hazen-Williams equation is used to calculate the friction losses in the system. For this example we will neglect the minor losses through fittings and valves. For systems with large numbers of fittings, the minor losses should be calculated as they can be significant. Note that the appropriate "C" factor for PVC pipe is 150.

Hazen-Williams Equation:

$$h_f = 10.654 \left(\frac{Q}{C} \right)^{0.54} \left(\frac{1}{D^{4.87}} \right) L = 10.654 \left(\frac{0.450 \text{ m}^3/\text{s}}{150} \right)^{0.54} \left(\frac{1}{(0.630 \text{ m})^{4.87}} \right) 3000 \text{ m} = 6.4 \text{ m}$$

The headloss due to friction is 6.4 meters of head or 63 kPa (9 psi). This friction head is added to the static head to get the total system head. Note: When using the Hazen-Williams equation with imperial units use the proper imperial form of the equation shown in section 2.

$$h_{\text{sys}} = 30 \text{ m} + 6.4 \text{ m} = 36.4 \text{ m or } 357 \text{ kPa (52 psi)}$$

Therefore, SDR51 with a long term rating (LTR) of 80 psi is adequate for the working pressure requirements of this system.

Step 3 – Calculate the short term (surge) requirements of the system

In section 2 a method to calculate the surge pressure for a given velocity change in a PVC pipe system was shown. The results of those calculations will be used here without reproducing the actual calculations again. To see exactly how these numbers were arrived at, refer to “Calculating Surge Pressures” in Section 2.

First calculate the actual maximum velocity of a 450 L/s flow in 600mm SDR51:

$$Q = va \therefore \frac{Q}{a} = \frac{.450\text{m}^3/\text{s}}{\left(\frac{\pi (0.630\text{m})^2}{4}\right)} = 1.44\text{m/s}$$

For every 0.3 m/s change in velocity, the surge pressure generated in SDR51 is 75 kPa (10.8psi).

$$P_s = \left(\frac{1.44\text{m/s}}{0.3}\right)75\text{kPa} = 360\text{kPa} (52 \text{ psi})$$

From Section 2 – the short term rating (STR) of SDR51 is 690 kPa (100psi)

Short term requirements of the system: 357kPa+360kPa= 717kPa (104 psi)

In this case SDR51 is slightly under designed for the short term rating, so we re-iterate the design using SDR41 with an STR of 130 psi. Since the I.D. is slightly different, and the surge generated slightly higher – we re-calculate steps 1 to 3 to obtain the following results:

$$h_{\text{sys}} = 30\text{m} + 6.8\text{m} = 36.8\text{m} \text{ or } 358\text{kPa} (52 \text{ psi})$$

$$P_s = \left(\frac{1.48\text{m/s}}{0.3}\right)79 = 389\text{kPa} (57 \text{ psi})$$

Short term requirements of the system: 358kPa + 389kPa = 747kPa (108psi)

STR of SDR41 = 130 psi (>108psi) therefore adequate for long-term and short-term requirements

Step 4 – Cyclic Analysis

Recent research by Dr. A. Moser at Utah State University with respect to cyclic fatigue in PVC pipes has both simplified and improved the accuracy of cyclic calculations. Note that the pressures used for the cyclic analysis are those that will occur during controlled start-up and shut down operations. The majority of today's pumping systems are equipped with soft start/stop capabilities, thus minimizing system shocks. The short-term system peak pressure (in this case 108 psi) is often not appropriate for cyclic analysis as it is the peak pressure that would be attained only during uncontrolled events (ie: a power outage), and is not cyclic in nature.

It was given that there are 36 cycles a day which means 36 startups and 36 shut downs for a total of 72 surge events per day.

Controlled max system pressure: 480 kPa (70 psi) {given}

Controlled minimum pressure: 207 kPa (30 psi) {given}

Calculate the average system stress:

$$\sigma_{\text{avg}} = \frac{(P_{\text{max}} + P_{\text{min}})(\text{DR}-1)}{4} = \frac{(480\text{kPa} + 207\text{kPa})(41-1)}{4} = 6879\text{kPa} (997 \text{ psi})$$

Calculate the stress amplitude:

$$\sigma_{\text{amp}} = \frac{(P_{\text{max}} - P_{\text{min}})(\text{DR}-1)}{4} = \frac{(480\text{kPa} - 207\text{kPa})(41-1)}{4} = 2730\text{kPa} (396 \text{ psi})$$

Figure 3 – Resulting Cyclic-Failure Curves for PVC

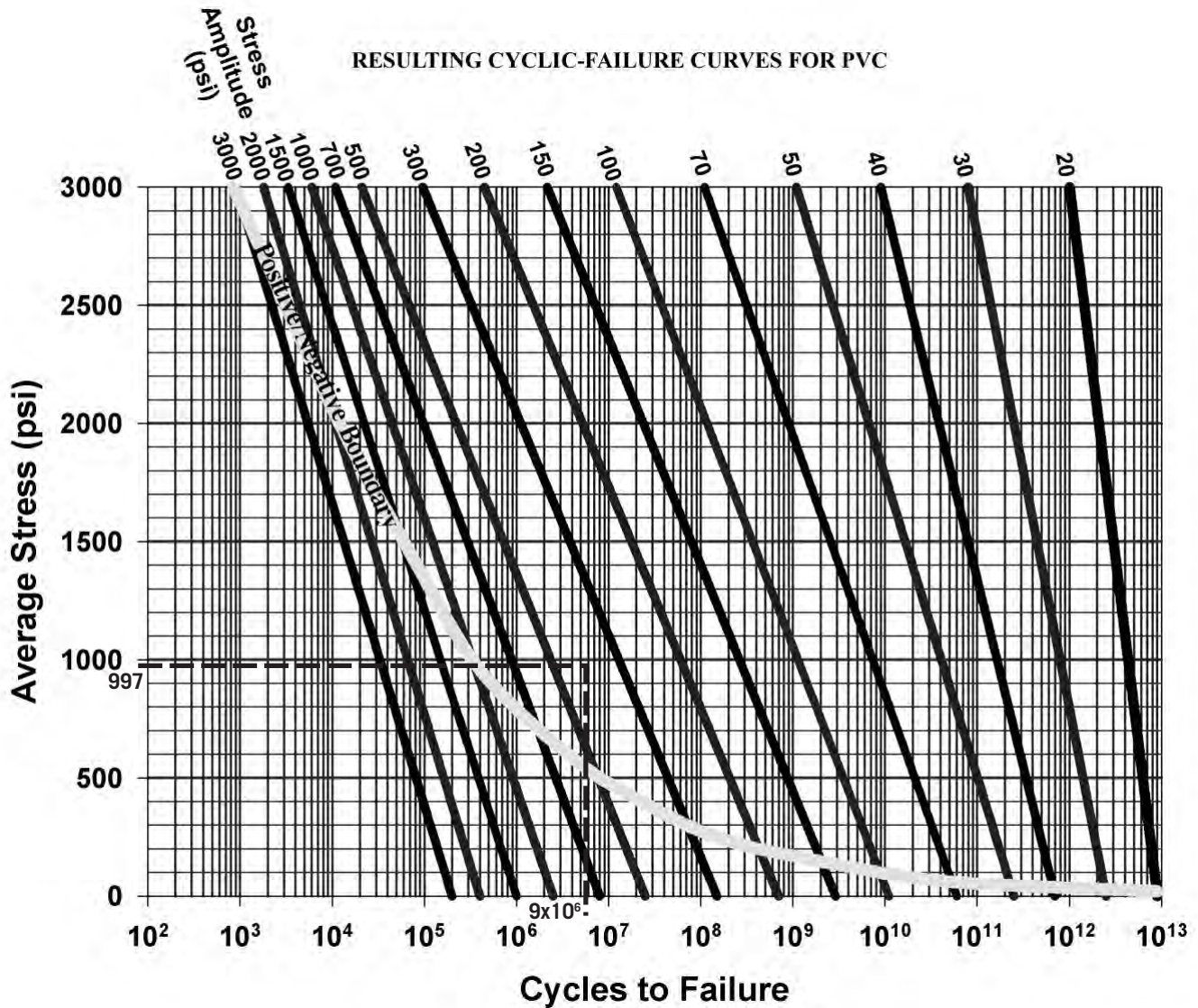

Determine the predicted number of cycles to failure using Moser's plot:

From the plot, the predicted cycles to failure are roughly 9×10^6 pump starts and stops.

Calculate cyclic life:

$72 \text{ events per day} \times 365 = 26,280 \text{ events per year}$

$9 \times 10^6 / 26280 = 342 \text{ years}$

Therefore SDR41 is more than adequate for the application

TRANSMISSION PIPE DESIGN EXAMPLE (TAKEN FROM AWWA M23 - PVC PIPE DESIGN & INSTALLATION MANUAL)

This analysis of a relatively simple pipeline will illustrate the use of the design principles discussed in this guide section. PVC pipe standards offer a variety of pipe strengths and sizes. Ideally, the designer will make selections that minimize capital and operating costs while maintaining an adequate design safety factor.

The project is a 20,000' long PVC water transmission main designed for an ultimate capacity of 4,000 gpm (5.76 mgd).

The profile of the pipeline is shown below. Water is being pumped to a ground storage tank (point f) with a maximum water level of 35' from the floor. The centerline of the discharge end of the main, at the tie-in to the storage tank, will be 5' below the tank floor.

Key stations and their elevations along the pipeline are:

Point	Station	Elevation at Pipe Centerline (ft)
a	0 + 00	600
b	45 + 00	670
c	75 + 00	720
d	115 + 00	800
e	165 + 00	940
f	200 + 00	940

Figure 4 – Pipeline Profile

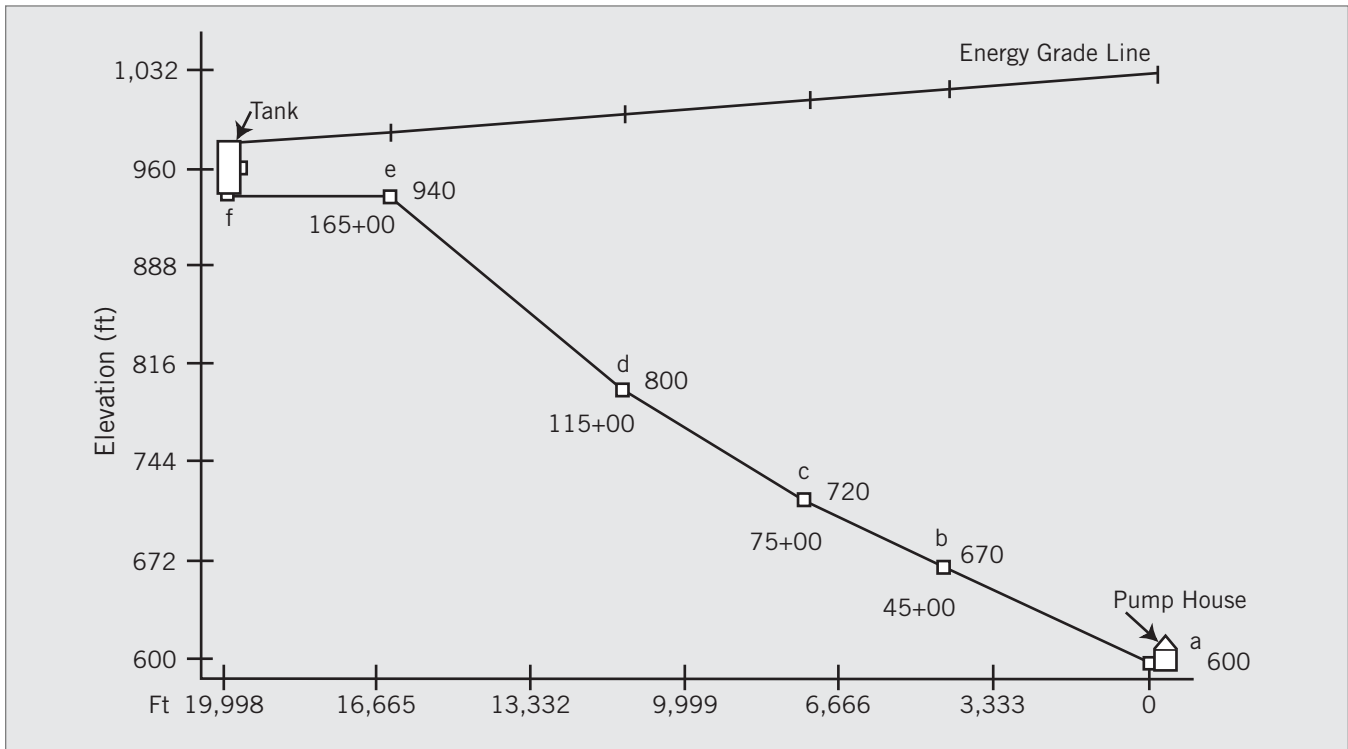

The objective of the design process will be to select proper DRs of PVC for appropriate sections of pipeline while never exceeding the PR nor the WPR of the pipe at any point. An effort will be made to select DRs that meet the design criteria while providing optimum economic value for the utility or owner.

The key determinant of PVC pressure pipe design is the internal pressure. The pipe dimensions can be found in the AWWA pipe standards. For this example, AWWA Standard C905, *Polyvinyl Chloride (PVC) Pressure Pipe and Fabricated Fittings, 14 In. Through 48 In. (350mm through 1,200mm), for Water Transmission and Distribution*, was used. The exact pipe dimensions are required to determine the flow velocity. The total pressure in the pipeline at any point is the sum of the static head, the friction loss, and the pressure rise as a result of sudden velocity changes. For simplicity, the selection of PVC pipe in this example will be limited to four PRs in CIOD only (PR 235, 165, 125 and 100).

Step 1 – Determine the maximum flow velocity

Assume that 20" PVC pipe will be used. In AWWA C905, the heaviest wall shown to be available in 20" pipe is DR 18. The assumption of beginning with the heaviest wall (i.e., the lowest DR) is recommended for most designs in the initial stage. The first assumption may be confirmed or revised as the design is developed.

$$\text{Average ID} = \text{Average OD} - 2 (\text{minimum wall thickness} \times 1.06)$$

Note: The tolerance on wall thickness is approximately +12%. There is no minus tolerance. Manufacturers will generally aim to produce PVC pressure pipe with wall thicknesses about 6% over minimum.

Assume: 20" DR 18 per AWWA C905

$$\begin{aligned} \text{Avg. ID} &= 21.60 - 2 (1.200 \times 1.06) \\ &= 19.05 \text{ in} = 1.59 \text{ ft} \end{aligned}$$

$$V = Q/A$$

Where,

$$Q = \text{Flow in ft}^3/\text{sec} = 4,000 \text{ gpm or } 8.91 \text{ ft}^3/\text{sec}$$

$$A = \text{area, ft}^2$$

$$V = \text{velocity, ft/sec}$$

$$A = (3.14) (1.59/2)^2 = 1.98 \text{ ft}^2$$

Therefore,

$$V = 8.91/1.98 = 4.5 \text{ ft/sec}$$

Because the velocity is within an acceptable range, the design may proceed with 20" pipe.

Step 2 – Determine the surge factor

In a transmission pipeline, the amplitude and location of the surge pressure envelope will often be analyzed by computer. For this example, the assumption has been made that the maximum surge pressure will be equal to an instantaneous stop-page of flow at full velocity. In practice, the costs of pipe materials may be significantly reduced through the use of appropriate surge control devices and proper pipeline operating procedures.

The pressure rise resulting from a $V = 4.5 \text{ ft/sec}$ instantaneous velocity change in PVC pressure pipes can be charted as follows:

Dimension Ratio, DR	1 ft/sec Surge, P_s' (psi)	$V \times P_s'$ (psi)
41	11.4	51.3
32.5	12.8	57.6
25	14.7	66.2
18	17.4	78.3

Step 3 – Determine the WPR for each of the DRs of Step 2

The WPR is a job-specific pressure rating of the pipe, taking into account the maximum possible surges versus the short-term strength of the pipe. The WPR may be either higher or lower than the PR of the pipe, depending on the flow conditions. The lower value between the WPR and the PR should be used as the upper limit for system steady-state operating pressure.

$$WPR = STR - V \times P_s'$$

DR	STR (psi)	V x P _s ' (psi)	WPR (psi)	PR (psi)
41	130	51.3	78.7	100
32.5	165	57.6	107.4	125
25	215	66.2	148.8	165
18	300	78.3	221.7	235

It can be seen that the governing parameter for the pressure design of this example will be the WPR analysis since it is lower than the PR of each DR.

Step 4 – Determine the friction loss f under full-flow conditions

Continue to assume DR 18 for this calculation because this pipe will produce slightly greater losses than the other DRs under consideration. The result will be conservative for all design operations.

The Hazen-Williams equation is convenient to use:

$$f = 0.2083 (100/C)^{1.852} \frac{Q^{1.852}}{d_i^{4.8655}}$$

Where,

f = friction head, ft of water per 100 ft of pipe

d_i = inside diameter of pipe, in.

Q = flow, gpm

C = flow coefficient, 150 for PVC

Substituting for 20" PR 235 pipe, where $d = 19.05$ in

$$\begin{aligned} f &= 0.273 \text{ ft of water per 100 ft of pipeline} \\ &= 0.118 \text{ psi per 100 ft (station) of pipeline} \end{aligned}$$

Step 5 – Determine the pressures at key points in the pipeline under steady-state, full-flow conditions

This pressure, P, at any point is the sum of the static head as a result of difference in elevations and the friction loss.

Referring to Figure 4, the pressure at key points can be calculated as follows:

Starting at the storage tank:

Station 200 + 00				
Static Head	=	980 – 940	=	40 ft
or 40 ft x (0.43 psi/ft)			=	17.3 psi
Station 165 + 00				
Static Head	=	(980 – 940) ft x (0.43 psi/ft)	=	17.3 psi
Friction Head	=	(3,500 ft) x (0.118 psi/100 ft)	=	4.1 psi
Total Head			=	21.4 psi
Station 115 + 00				
Static Head	=	(980 – 800) ft x (0.43 psi/ft)	=	77.4 psi
Friction Head	=	(8,500 ft) x (0.118 psi/100 ft)	=	10.0 psi
Total Head			=	87.4 psi
Station 75 + 00				
Static Head	=	(980 – 720) ft x (0.43 psi/ft)	=	111.8 psi
Friction Head	=	(12,500 ft) x (0.118 psi/100 ft)	=	14.8 psi
Total Head			=	126.6 psi
Station 45 + 00				
Static Head	=	(980 – 670) ft x (0.43 psi/ft)	=	133.3 psi
Friction Head	=	(15,500 ft) x (0.118 psi/100 ft)	=	18.3 psi
Total Head			=	151.6 psi
Station 0 + 00				
Static Head	=	(980 – 600) ft x (0.43 psi/ft)	=	163.4 psi
Friction Head	=	(20,000 ft) x (0.118 psi/100 ft)	=	23.6 psi
Total Head			=	187.0 psi

The pressure, P, at each of the key points are summarized as follows:

Point	Station	Static Head (psi)	Friction Head (psi)	Pressure, P (psi)
f	200 + 00	17.3	0	17.3
e	165 + 00	17.3	4.1	21.4
d	115 + 00	77.4	10.0	87.4
c	75 + 00	111.8	14.8	126.6
b	45 + 00	133.3	18.3	151.6
a	0 + 00	163.4	23.6	187.0

Step 6 – Determine the appropriate DR of pipe for each section of the pipeline

From previous calculations in Step 3, DR 18 PVC pressure pipe has a working pressure rating 221.7 psi. For the next greater DR, DR 25, the WPR is 148.8 psi. Therefore, DR 18 is selected to start out at the pumphouse until a point in the system where the operating pressure, P, drops to be equal to the WPR of DR 25. At this point, DR 25 may be used. Subsequent steps will determine the starting points for DR 32.5 as well as DR 41.

It can be seen from the above summary of pressures by section that the transition to DR 25 will occur between Stations 45 + 00 and 75 + 00, in section bc. To pinpoint the exact location, the pressure gradient for that section must be calculated.

$$\begin{aligned}\Delta P(bc) &= \frac{(P_c + P_b)}{\text{Station Length of bc}} \\ &= \frac{126.6 \text{ psi} - 151.6 \text{ psi}}{(75 - 45) \times (100 \text{ ft})} \\ &= -0.83 \text{ psi/100 ft}\end{aligned}$$

The length beyond Station 45 + 00 (point b) can be calculated as follows:

$$\begin{aligned}\text{Station Length} &= \frac{\text{WPR(DR 25)} - P_b}{\Delta P(bc)} \\ &= \frac{(148.8 \text{ psi}) - (151.6 \text{ psi})}{-0.83 \text{ psi/100 ft}} \\ &= 337 \text{ ft (i.e., at 337 ft downstream of Station 45 + 00)}\end{aligned}$$

Therefore, begin using DR 25 at Station 48 + 37.

Similarly, the transition point for DR 32.5 can be found.

From the summary of pressures and knowing the WPR of DR 32.5 is 107.4 psi, DR 32.5 can be used between Station 75 + 00 and Station 115 + 00, i.e., section cd.

First, calculate the pressure gradient in section cd.

$$\begin{aligned}\Delta P(cd) &= \frac{(P_d - P_c)}{\text{Station Length of cd}} \\ &= \frac{87.4 \text{ psi} - 126.6 \text{ psi}}{(115 - 75) \times (100 \text{ ft})} \\ &= -0.98 \text{ psi/100 ft}\end{aligned}$$

Next, the Station Length beyond Station 75 + 00 can be calculated:

$$\begin{aligned}\text{Station Length} &= \frac{\text{WPR(DR 32.5)} - P_c}{\Delta P(cd)} \\ &= \frac{(107.4 \text{ psi}) - (126.6 \text{ psi})}{-0.98 \text{ psi/100 ft}} \\ &= 1,959 \text{ ft (i.e., at 1,959 ft downstream of Station 75 + 00)}\end{aligned}$$

Therefore, begin using DR 32.5 at Station 94 + 59.

Similarly, it can be calculated where DR 41 usage may begin.

From review of the summary of pressures and knowing the WPR of DR 41 is 78.7 psi, the range for DR 41 begins between Station 115 + 00 and Station 165 + 00, i.e., section de.

First, calculate the pressure gradient in section de.

$$\begin{aligned} \Delta P(de) &= \frac{(P_e - P_d)}{\text{Station Length of de}} \\ &= \frac{21.4 \text{ psi} - 87.4 \text{ psi}}{(165 - 115) \times (100 \text{ ft})} \\ &= -1.32 \text{ psi/100 ft} \end{aligned}$$

Next, the Station Length beyond point d:

$$\begin{aligned} \text{Station Length} &= \frac{\text{WPR(DR 41)} - P_d}{\Delta P(de)} \\ &= \frac{(78.7 \text{ psi}) - (87.4 \text{ psi})}{-1.32 \text{ psi/100 ft}} \\ &= 659 \text{ ft (i.e., at 659 ft downstream of Station 115 + 00)} \end{aligned}$$

Therefore, DR 41 may begin usage at Station 121 + 59 and continue for the duration of the pipeline up to its terminus at the reservoir.

The design for internal pressure may be summarized as follows:

Distance from Pumphouse (ft)	Use 20 in.	Pressure Gradient (psi)
0 – 4,837	DR 18 (PR 235)	187.0 – 148.8
4,837 – 9,459	DR 25 (PR 165)	148.8 – 107.4
9,459 – 12,159	DR 32.5 (PR 125)	107.4 – 78.7
12,159 – 20,000	DR 41 (PR 100)	78.7 – 17.3

In this example of a 3.8 mile pipeline, the designer has the opportunity to make significant cost savings through the use of several PVC pipe pressure ratings. Computer modeling may disclose even further potential savings by showing exactly where and how surge control is most effective. (Note that the above pipe selection was made assuming that the potential exists for the instantaneous stoppage of flow.)

If the pipeline is operated in a cycle mode (i.e., like some sewage force mains), an analysis of fatigue life should be made. Both present and future modes of operation should be examined.

SECTION FOUR: APPENDICES

APPENDIX A: REFERENCES

- 1 Duranceau, Schiff, Bell. "Electrical Grounding, Pipe Integrity and Shock Hazard", Journal of the AWWA, July 1998, pp. 40-51
- 2 Hulsmann, Nowack, "70 Years of Experience with PVC Pipes" Conference Paper, Plastic Pipes XII, Milan, April 2004
- 3 Jenkins, Thompson, "Review of Water Industry Plastic Pipe Practices", AWWA Research Foundation, 1987
- 4 Berens, A.R., "Prediction of Chemical Permeation through PVC Pipe", Journal of the AWWA, November 1985
- 5 Hoogensen Metallurgical Engineering Ltd., "Examination of Submitted PVC Pipe Section", Report to IPEX, December 1998
- 6 Uni-Bell PVC Pipe Association, "Handbook of PVC Pipe – Design and Construction", fourth edition, (August 2001)

APPENDIX B: REFERENCE TABLES AND CONVERSION CHARTS

Table B-1	Pipe Capacity
Table B-2	Weights of Water
Table B-3	Decimal & Millimeter Equivalents of Fractions
Table B-4	Volume Conversion
Table B-5	Pressure Conversion
Table B-6	Flow Conversion
Table B-7	Temperature Conversion
Table B-8	Length Conversion

APPENDIX C: USEFUL FORMULAS

- Area of a Circle
- Circumference of a Circle
- Length of Circular Arc
- Area of Circle Sector
- Equation of a Circle (cartesian coordinates)
- Equation of a Line (quadratic formula)
- Basic Trigonometric Functions
- Area of an Ellipse
- Circumference of an Ellipse
- Area of a Triangle
- Area of a Trapezoid
- Area of a Parallelogram
- Surface Area of a Sphere
- Volume of a Sphere
- Surface Area of a Cylinder
- Volume of a Cylinder
- Surface Area of an Elliptical Tank
- Volume of an Elliptical Tank
- Surface Area of a Cone
- Volume of a Cone
- Surface Area of a Rectangular Solid
- Volume of a Rectangular Solid

TABLE B-1 PIPE CAPACITY

Pipe Size (in.)	Outside Diameter – IPS OD Pipe			Volume for 1 foot length of pipe				
	inch	feet	cm	in ³	ft ³	cm ³	US Gal	Imp Gal
1/4	0.250	0.021	0.098	0.589	0.0003	9.648	0.003	0.002
3/8	0.375	0.031	0.148	1.325	0.001	21.708	0.006	0.005
1/2	0.500	0.042	0.197	2.355	0.001	38.591	0.010	0.008
3/4	0.750	0.063	0.295	5.299	0.003	86.831	0.023	0.019
1	1.000	0.083	0.394	9.420	0.005	154.366	0.041	0.034
1-1/4	1.250	0.104	0.492	14.719	0.009	241.196	0.064	0.053
1-1/2	1.500	0.125	0.591	21.195	0.012	347.322	0.092	0.076
2	2.000	0.167	0.787	37.680	0.022	617.462	0.163	0.136
3	3.000	0.250	1.181	84.780	0.049	1,389.290	0.367	0.306
4	4.000	0.333	1.575	150.720	0.087	2,469.849	0.652	0.543
5	5.000	0.417	1.969	235.500	0.136	3,859.139	1.019	0.849
6	6.000	0.500	2.362	339.120	0.196	5,557.159	1.468	1.222
8	8.000	0.667	3.150	602.880	0.349	9,879.395	2.610	2.173
10	10.000	0.833	3.937	942.000	0.545	15,436.554	4.078	3.396
12	12.000	1.000	4.724	1,356.480	0.785	22,228.638	5.872	4.890
14	14.000	1.167	5.512	1,846.320	1.068	30,255.646	7.993	6.655
16	16.000	1.333	6.299	2,411.520	1.396	39,517.578	10.439	8.693
18	18.000	1.500	7.087	3,052.080	1.766	50,014.435	13.212	11.002
20	20.000	1.667	7.874	3,768.000	2.181	61,746.216	16.312	13.582
24	24.000	2.000	9.449	5,425.920	3.140	88,914.551	23.489	19.559

TABLE B-2 WEIGHTS OF WATER

Units of Volume	Weight	
	pounds	kilograms
1 US Gallon	8.350	3.791
1 Imperial Gallon	10.020	4.549
1 litre	2.210	1.003
1 cubic yard	1,685.610	765.267
1 cubic foot	62.430	28.343
1 cubic inch	0.036	0.016
1 cubic cm	0.002	0.001
1 cubic metre	2,210.000	1,000.000

TABLE B-3 DECIMAL & MILLIMETER EQUIVALENTS OF FRACTIONS

Inches		Millimeters	Inches		Millimeters
Fractions	Decimals		Fractions	Decimals	
1/64	0.015625	0.397	33/64	0.515625	13.097
1/32	0.03125	0.794	17/32	0.53125	13.494
3/64	0.046875	1.191	35/64	0.546875	13.891
1/16	0.0625	1.588	9/16	0.5625	14.288
5/64	0.078125	1.984	37/64	0.578125	14.684
3/32	0.09375	2.381	19/32	0.59375	15.081
7/64	0.109375	2.778	39/64	0.609375	15.478
1/8	0.125	3.175	5/8	0.625	15.875
9/64	0.140625	3.572	41/64	0.640625	16.272
5/32	0.15625	3.969	21/32	0.65625	16.669
11/64	0.171875	4.366	43/64	0.671875	17.066
3/16	0.1875	4.763	11/16	0.6875	17.463
13/64	0.203125	5.159	45/64	0.703125	17.859
7/32	0.21875	5.556	23/32	0.71875	18.256
15/64	0.234375	5.953	47/64	0.734375	18.653
1/4	0.250	6.350	3/4	0.750	19.050
17/64	0.265625	6.747	49/64	0.765625	19.447
9/32	0.28125	7.144	25/32	0.78125	19.844
19/64	0.296875	7.541	51/64	0.796875	20.241
5/16	0.3125	7.938	13/16	0.8125	20.638
21/64	0.328125	8.334	53/64	0.828125	21.034
11/32	0.34375	8.731	27/32	0.83475	21.431
23/64	0.359375	9.128	55/64	0.859375	21.828
3/8	0.375	9.525	7/8	0.875	22.225
25/64	0.390625	9.922	57/64	0.890625	22.622
13/32	0.40625	10.319	29/32	0.90625	23.019
27/64	0.421875	10.716	59/64	0.921875	23.416
7/16	0.4375	11.113	15/16	0.9375	23.813
29/64	0.453125	11.509	61/64	0.953125	24.209
15/32	0.46875	11.906	31/32	0.96875	24.606
31/64	0.484375	12.303	63/64	0.984375	25.003
1/2	0.500	12.700	1	1.000	25.400

TABLE B-4 VOLUME CONVERSION

Units of Volume	in ³	ft ³	yd ³	cm ³	m ³	liter	U.S. gal.	Imp. gal.
cubic inch	1	0.00058	-	16.387	-	0.0164	0.0043	0.0036
cubic foot	1728	1	0.0370	28,317.8	0.0283	28.32	7.481	6.229
cubic yard	46,656	27	1	-	0.7646	764.55	201.97	168.8
cubic centimeter	0.0610	-	-	1	-	0.001	0.0003	0.0002
cubic meter	61,023.7	35.31	1.308	-	1	1000	264.17	220.0
liter	61.02	0.0353	0.0013	1000	0.001	1	0.2642	0.22
U.S. gallon	231	0.1337	0.0050	3785.4	0.0038	3.785	1	0.8327
Imp. gallon	277.42	0.1605	0.0059	4546.1	0.0045	4.546	1.201	1

TABLE B-5 PRESSURE CONVERSION

Units of Pressure	atm	bar	lb/in ²	lb/ft ²	kg/cm ²	kg/m ²	inch H ₂ O	inch Hg	inch air	ft H ₂ O	ft air	mm Hg	mm H ₂ O	kilopascal	N/m ²
atmosphere (atm)	1	0.987	0.068	-	0.968	-	0.002	0.033	-	0.029	-	0.001	-	0.01	-
bar	1.013	1	0.069	-	0.981	-	0.002	0.034	-	0.03	-	0.001	-	0.01	-
pound per square inch (psi)	14.7	14.5	1	0.007	14.22	0.001	0.036	0.491	-	0.434	0.001	0.019	0.001	0.145	-
pound per square foot (psf)	2,116	2,089	144	1	2,048	0.205	5.2	70.73	0.006	62.43	0.076	2.784	0.205	20.89	0.021
kilogram per square centimeter	1.033	1.02	0.07	-	1	0.0001	0.003	0.035	-	0.03	-	0.001	-	0.01	-
kilogram per square meter	10,332	10,197	703	4.88	10,000	1	25.4	345.3	0.031	304.8	0.373	13.6	1	101.97	0.102
inch of water (H ₂ O) (4°C)	406.78	401.46	27.68	0.192	393.7	0.039	1	13.6	0.001	12	0.015	0.535	0.039	4.015	0.004
inch of mercury (Hg) (0°C)	29,921	29,53	2,036	0.014	28,96	0.003	0.074	1	-	0.883	0.001	0.039	0.003	0.295	-
inch of air (15°C)	332,005	327,664	22,592	148.7	321,328	32.13	816.2	11,096	1	9,794	12	436.8	32.13	3,277	3.106
foot of water (4°C)	33.9	33.46	2.307	0.016	32.81	0.003	0.083	1.133	-	1	-	0.045	0.003	0.335	-
foot of air (15°C)	27,677	27,305	1,883	13.07	26,777	2.678	0.006	924.7	0.083	816.2	1	36.4	2.678	273.1	0.273
millimeter of mercury (0°C)	760	750	51.71	0.36	735.6	0.074	1.868	25.4	0.002	22.42	0.027	1	0.074	7.5	0.008
millimeter of water (4°C)	10,332	10,197	703	4.88	10,000	1	25.4	345.3	0.031	304.8	0.373	13.6	1	101.97	0.102
kilopascal (kPa)	101.3	100	6.89	0.048	98.07	0.01	0.249	3.386	-	2.99	0.004	0.133	0.01	1	0.001
Newton per square meter	-	-	-	0.021	-	0.102	0.004	-	3.277	-	0.273	0.008	0.102	0.001	1

TABLE B-6 FLOW CONVERSION

Units of Flow Rate	US gps	US gpm	US gph	US gpd	Imp gps	Imp gpm	Imp gph	Imp gpd	liters/sec	liters/min	liters/hr	liters/day
US gal/sec (gps)	1	0.017	-	-	1.2	0.02	-	-	0.264	0.004	-	-
US gal/min (gpm)	60	1	0.017	0.001	72.06	1.2	0.02	0.001	15.85	0.264	0.004	-
US gal/hr (gph)	3,600	60	1	0.042	4,323	72.06	1.2	0.05	951.02	15.85	0.264	0.011
US gal/day (gpd)	86,400	1,440	24	1	103,762	1,729.40	28.82	1.2	22,824	380.41	6.34	0.264
Imperial gal/sec	0.833	0.014	-	-	1	0.017	-	-	0.22	0.004	-	-
Imperial gal/min	49.96	0.833	0.014	0.001	60	1	0.017	0.001	13.2	0.22	0.004	-
Imperial gal/hr	2,997.60	49.96	0.833	0.035	3,600	60	1	0.042	791.89	13.2	0.22	0.009
Imperial gal/day	71,943	1,199	19.98	0.833	86,400	1,440	24	1	19,005	316.76	5.279	0.22
Liters/sec	3.79	0.063	0.002	-	4.55	0.076	0.001	-	1	0.017	-	-
Liters/min	227.12	3.785	0.063	0.003	272.77	4.55	0.076	0.003	60	1	0.017	0.001
Liters/hr	13,627	227.12	3.785	0.158	16,366	272.77	4.55	0.189	3,600	60	1	0.042
Liters/day	327,060	5,451	90.85	3.785	392,782	6,546	109.11	4.55	86,400	1,440	24	1
Cubic ft/sec (cfs)	0.134	0.002	-	-	0.161	0.003	-	-	0.035	0.001	-	-
Cubic ft/min (cfm)	8.02	0.134	0.002	-	9.633	0.161	0.003	-	2.119	0.035	0.001	-
Cubic ft/hr (cfh)	481.25	8.02	0.134	0.006	577.96	9.63	0.161	0.007	127.13	2.119	0.035	0.001
Cubic ft/day (cfd)	11,550	192.5	3.21	0.134	13,871	231.18	3.853	0.161	3,051.20	50.85	0.848	0.001
Acre in/min	0.002	-	-	-	0.003	-	-	-	0.001	-	-	-
Acre in/hr	0.133	0.002	-	-	0.159	0.003	-	-	0.035	-	-	-
Acre in/day	3.182	0.053	0.001	-	3.821	0.064	0.001	-	0.841	0.001	-	-
Cubic m/sec	0.004	-	-	-	0.005	-	-	-	0.001	-	-	-
Cubic m/min	0.227	0.004	-	-	0.273	0.005	-	-	0.06	0.001	-	-
Cubic m/hr	13.628	0.227	0.004	-	16.366	0.273	0.005	-	3.6	0.06	0.001	-
Cubic m/day	327.06	5.451	0.091	0.004	392.78	6.546	0.109	0.005	86.4	1.44	0.024	0.001

Units of Flow Rate	ft ³ /sec	ft ³ /min	ft ³ /hr	ft ³ /day	Acre in/min	Acre in/hr	Acre in/day	m ³ /sec	m ³ /min	m ³ /hr	m ³ /day
US gal/sec (gps)	7.48	0.125	0.002	-	452.6	7.54	0.31	264.2	4.4	0.073	0.003
US gal/min (gpm)	448.8	7.48	0.125	0.005	27,154	452.6	18.86	15,850	264.2	4.403	0.183
US gal/hr (gph)	26,930	448.83	7.481	0.312	1.629E+06	27,154	1,131	951,019	15,850	264.17	11.007
US gal/day (gpd)	646,317	10,772	179.53	7.481	3.910E+07	651,703	27,154	2.282E+07	380,408	6,340	264.17
Imperial gal/sec	6.229	0.104	0.002	-	376.8	6.28	0.26	220	3.67	0.061	0.003
Imperial gal/min	373.73	6.229	0.104	0.004	22,611	376.8	15.7	13,198	220	3.666	0.153
Imperial gal/hr	22,424	373.73	6.229	0.259	1.357E+06	22,611	942.1	791,889	13,198	220	9.165
Imperial gal/day	538,171	8,970	149.49	6.229	3.256E+07	542,656	22,611	1.901E+07	316,756	5,279	220
Liters/sec	28.32	0.472	0.008	-	1,713	28.6	1.19	1,000	16.67	0.278	0.012
Liters/min	1,699	28.32	0.472	0.2	102,790	1,713	71.38	60,000	1,000	16.67	0.694
Liters/hr	101,941	1,669	28.32	1.18	6.167E+06	102,790	4,283	3.600E+06	60,000	1,000	42.67
Liters/day	2,446,575	40,776	679.6	28.32	1.480E+08	2.467E+06	102,790	8.640E+07	1.440E+06	24,000	1,000
Cubic ft/sec (cfs)	1	0.017	-	-	60.5	1.008	0.042	35.31	0.589	0.01	-
Cubic ft/min (cfm)	60	1	0.017	-	3,630	60.5	2.52	2,119	35.31	0.59	0.025
Cubic ft/hr (cfh)	3,600	60	1	0.042	217,800	3,630	151.25	127,133	2,119	35.31	1.471
Cubic ft/day (cfd)	86,400	1,440	24	1	5.227E+06	87,120	3,630	3,051,187	50,853	847.55	35.31
Acre in/min	0.017	-	-	-	1	0.017	0.001	0.584	0.01	-	-
Acre in/hr	0.992	0.001	-	-	60	1	0.042	35.02	0.584	0.01	-
Acre in/day	23.8	0.033	0.006	-	1,440	24	1	840.55	14.001	0.233	0.001
Cubic m/sec	0.028	-	-	-	1.71	0.029	0.001	1	0.017	-	-
Cubic m/min	1.7	0.028	-	-	102.8	1.71	0.071	60	1	0.017	0.001
Cubic m/hr	101.94	1.7	0.028	0.001	6,167	102.8	4.283	3,600	60	1	0.042
Cubic m/day	2446.6	40.78	0.68	0.028	148,018	2,467	102.79	86,400	1,400	24	1

TABLE B-7 TEMPERATURE CONVERSION

°F	°C	°F	°C	°F	°C	°F	°C	°F	°C
-60	-51	22	-5.6	50	10.0	78	25.6	160	71
-50	-46	23	-5.0	51	10.6	79	26.1	170	77
-40	-40	24	-4.4	52	11.1	80	26.7	180	82
-30	-34	25	-3.9	53	11.7	81	27.2	190	88
-20	-29	26	-3.3	54	12.2	82	27.8	200	92
-10	-23.0	27	-2.8	55	12.8	83	28.3	210	99
0	-17.8	28	-2.2	56	13.3	84	28.9	212	100
1	-17.2	29	-1.7	57	13.9	85	29.4	220	104
2	-16.7	30	-1.1	58	14.4	86	30.0	230	110
3	-16.1	31	-0.6	59	15.0	87	30.6	240	116
4	-15.6	32	0.0	60	15.6	88	31.1	250	121
5	-15.0	33	0.6	61	16.1	89	31.7	260	127
6	-14.4	34	1.1	62	16.7	90	32.2	270	132
7	-13.9	35	1.7	63	17.2	91	32.8	280	138
8	-13.3	36	2.2	64	17.8	92	33.3	290	143
9	-12.8	37	2.8	65	18.3	93	33.9	300	149
10	-12.2	38	3.3	66	18.9	94	34.4	310	154
11	-11.7	39	3.9	67	19.4	95	35.0	320	160
12	-11.1	40	4.4	68	20.0	96	35.6	330	166
13	-10.6	41	5.0	69	20.6	97	36.1	340	171
14	-10.0	42	5.6	70	21.1	98	36.7	350	177
15	-9.4	43	6.1	71	21.7	99	37.2	360	182
16	-8.9	44	6.7	72	22.2	100	37.8	370	188
17	-8.3	45	7.2	73	22.8	110	43	380	193
18	-7.8	46	7.8	74	23.3	120	49	390	199
19	-7.2	47	8.3	75	23.9	130	54	400	204
20	-6.7	48	8.9	76	24.4	140	60		
21	-6.1	49	9.4	77	25.0	150	66		

Degrees Celsius $^{\circ}\text{C} = \frac{5}{9} (^{\circ}\text{F} - 32)$

Degrees Fahrenheit $^{\circ}\text{F} = \frac{9}{5} ^{\circ}\text{C} + 32$

Degrees Kelvin $^{\circ}\text{T} = ^{\circ}\text{C} + 273.2$

Degrees Rankine $^{\circ}\text{R} = ^{\circ}\text{F} + 459.7$

TABLE B-8 LENGTH CONVERSION

Units of Length	in.	ft.	yd.	mile	mm	cm	m	km
inch	1	0.0833	0.0278	-	25.4	2.54	0.0254	-
foot	12	1	0.3333	-	304.8	30.48	0.3048	-
yard	36	3	1	-	914.4	91.44	0.9144	-
mile	-	5280	1760	1	-	-	1609.3	1.609
millimeter	0.0394	0.0033	-	-	1	0.100	0.001	-
centimeter	0.3937	0.0328	0.0109	-	10	1	0.01	-
meter	39.37	3.281	1.094	-	1000	100	1	0.001
kilometer	-	3281	1094	0.6214	-	-	1000	1

(1 micron = 0.001 millimeter)

APPENDIX C: USEFUL FORMULAS

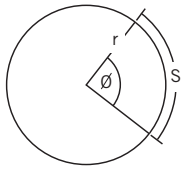

Circle

Diameter = $2R$ _____

Circumference = $\pi D = 2\pi R$

Area = πR^2

Length of Circular Arc

$$S = \theta \times \left(\frac{\pi}{180}\right) \times r \quad \theta \text{ in degrees}$$

$$S = \theta \times r \quad \theta \text{ in radians}$$

Area of Circle Sector

$$A = \theta \times \left(\frac{\theta}{360}\right) \times \pi \times r^2 \quad \theta \text{ in degrees}$$

$$A = \theta \times \left(\frac{\theta}{2}\right) \times r^2 \quad \theta \text{ in radians}$$

Equation of a Circle (cartesian co-ordinates)

- for a circle with center (j, k) and radius (r)

$$(x - j)^2 + (y - k)^2 = r^2$$

Equation of a line (quadratic formula)

$$ax + by + c = 0$$

or

$$ax^2 + bx + c = 0$$

$$x = \frac{-b \pm \sqrt{b^2 - 4ac}}{2a}$$

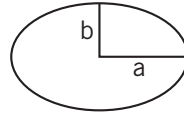

Ellipse

Area = $\pi \times a \times b$

Circumference = $\frac{1 + 4(a-b)^2}{((3a + 5b)(5a + 3b))}$

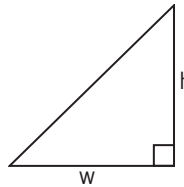

Triangle

Area = $\frac{w \times h}{2}$

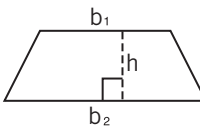

Trapezoid

Area = $\frac{1}{2} (b_1 + b_2) \times h$

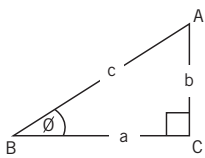

Trigonometry

$$\sin \theta = \frac{b}{c}$$

$$\cos \theta = \frac{a}{c}$$

$$\tan \theta = \frac{b}{a}$$

Sine Law

$$\frac{a}{\sin A} = \frac{b}{\sin B} = \frac{c}{\sin C} = 2R$$

Cosine Law

$$C^2 = a^2 + b^2 - 2ab \cos C$$

$$b^2 = a^2 + c^2 - 2ac \cos B$$

$$a^2 = b^2 + c^2 - 2bc \cos A$$

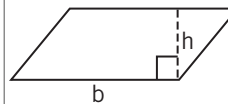

Parallelogram

Area = $b \times h$

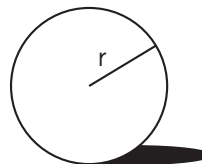

Sphere

Surface Area = $4 \pi r^2$

Volume = $\frac{4}{3} \pi r^3$

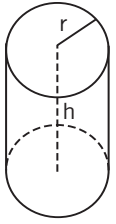

Cylinder

$$\text{Surface Area} = (2 \pi r^2) + (2 \pi r h)$$

$$\text{Volume} = \pi r^2 h$$

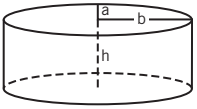

Elliptical Tank

$$\text{Surface Area} = 2 \pi \left(\frac{\sqrt{a^2 + b^2}}{2} \right) h + (2\pi ab)$$

$$\text{Volume} = \pi abh$$

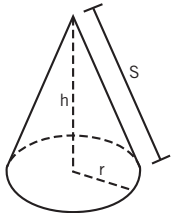

Cone

$$\text{Surface Area} = \pi r S$$

$$\text{Volume} = \pi r^2 \times \frac{h}{3}$$

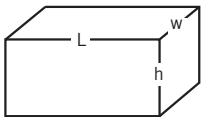

Rectangular Solid

$$\text{Surface Area} = 2 (Lw + Lh + wh)$$

$$\text{Volume} = L \times w \times h$$

APPENDIX D: ABBREVIATIONS

AGA	- American Gas Association
ANSI	- American National Standards Institute
API	- American Petroleum Institute
ASME	- American Society of Mechanical Engineers
ASTM	- American Society for Testing and Materials
AWWA	- American Water Works Association
BOCA	- Building Officials and Code Administrators
BS	- British Standards Institution
CPVC	- Chlorinated poly (vinyl chloride) plastic or resin
CS	- Commercial Standard, see Product Standard
CSA	- Canadian Standards Association
DR	- Dimension Ratio
DIN	- German Industrial Norms
FHA	- Federal Housing Administration or Farmers Home Administration
HDB	- Hydrostatic design basis
HDS	- Hydrostatic design stress
IAPD	- International Association of Plastics Distributors
IAPMO	- International Association of Plumbing and Mechanical Officials
IPC	- International Plumbing Code
ISO	- International Standards Organization
JIS	- Japanese Industrial Standards
NSF	- National Sanitation Foundation International
PPI	- Plastics Pipe Institute
PS	- Product Standard when in reference to a specification for plastic pipe and fittings. These specifications are promulgated by the U.S. Department of Commerce and were formerly known as Commercial Standards.
PSI	- Pounds per square inch
PSIG	- Gage pressure in pounds per square inch
PVC	- Poly (vinyl chloride) plastic or resin
RVCM	- Residual Vinyl Chloride Monomer
SCS	- Soil Conservation Service
SDR	- Standard Dimension Ratio
SI	- International System of Units
SPI	- Society of the Plastics Industry, Inc.
UPC	- Uniform Plumbing Code
USASI	- United States of America Standards Institute (formerly American Standards Association)
WOG	- Water, Oil, Gas

APPENDIX E: TABLES AND FIGURES

Table 1	Percent (%) Deflection for IPEX Centurion Pressure Pipe
Table 2	Q-Line Flow Rates
Table 3	Summary of Properties
Table 4	Temperature Effects on PVC Pressure Pipe
Table 5	AWWA C900 Pressure Classes
Table 6	Hazen-Williams "C"-Factors
Table 7	Thrust Developed per 100 psi Pressure (lbs. force)
Figure 1	Stress Regression Line - 12454
Figure 2	Pipe Material
Figure 3	Resulting Cyclic-Failure Curves for PVC
Figure 4	Pipeline Profile

Blue Brute Fittings

Blue Brute fittings are injection molded and are even tougher than the pipe. Injection molded Blue Brute fittings have a wall thickness 125% larger than SDR18 pipe, and custom-made fabricated fittings are wrapped with a tough layer of fiberglass for extra protection.



Corrosion-Proof Performance

Blue Brute systems are immune to corrosion from aggressive soils and galvanic action.

Superior Hydraulics

The glass-like finish of PVC reduces friction losses and eliminates the tuberculation common in iron pipes. As a result, pumping costs are reduced and water quality is maintained.

Strength

A thicker bell that results in a more robust fitting.

Gaskets Options

All Blue Brute fittings are shipped with standard gaskets that accept cast-iron-sized PVC pipe. Transition gaskets for IPS-sized pipe are an option for all sizes. For applications where fittings must be buried in soil with hydrocarbon contamination, Nitrile gaskets are available.

Saves Time & Money

A consistent O.D. for each size, simplifying the restraint selection. Each fitting is labeled with the O.D. information for easy identification and restraint selection.

Third-party Certification

All IPEX municipal systems are third-party certified as applicable. In addition, IPEX Centurion and Blue Brute systems have Factory Mutual approval and Underwriter's Laboratories (ULI and ULC) listings.



MUNICIPAL PRESSURE PIPING SYSTEMS

NEW PRODUCT SHOWCASE



IPEX offers “more robust” fabricated fittings in sizes 4" to 16" for use on C900 and C905 pipe

IPEX is now offering a new and improved fabricated fitting for Blue Brute and Centurion pressure piping systems. Designed with a thicker bell, the standardized fitting provides a more robust bell than any other fabricated C900/C905 fitting currently offered in North America.

The new bells also have the same O.D. and thickness as the bells on Blue Brute and Centurion pipes providing a consistent O.D. throughout the entire offering.

FEATURES AND BENEFITS:

- A thicker bell that results in a more robust fitting.
- A consistent O.D. for each size, simplifying the restraint selection.
- Each fitting is labeled with the O.D. information for easy identification and restraint selection.

CLASSIFICATIONS:

- PVC Pressure Systems manufactured to the performance requirements of AWWA and CSA Standards

STANDARD PRODUCT OFFERING

4" (100mm) to 16" (400mm) - PR 235psi (DR18)

Note: Other DR's and sizes up to 48" (1200mm) are available upon request.

Bell OD for Joint Restraint Selection Diamètre Ext. de cloche pour sélection du collet de retenue			
OD-DE		MIN.	MAX.
100mm (4")		5.44"	5.61"
150mm (6")		7.84"	8.03"
200mm (8")		10.29"	10.55"
250mm (10")		12.63"	12.96"
300mm (12")		15.07"	15.46"
350mm (14")		17.28"	17.73"
400mm (16")		19.64"	20.17"



Products are manufactured by IPEX Inc. and distributed in the United States by IPEX USA LLC. Blue Brute® & Centurion® are trademarks of IPEX Branding Inc.

Canadian Customers call IPEX Inc.

Toll Free: (866) 473-9462

www.ipexinc.com

IPEX Centurion

14" - 48" (350mm - 1200mm)

IPEX Centurion extends the corrosion-free benefits of Blue Brute to larger diameters of pipe and new applications. The versatility and ease of installation of IPEX Centurion is unmatched – shop drawings are eliminated and costly and difficult to install corrosion protection can be eliminated. In addition, unlike HDPE or concrete pressure pipe, every length of IPEX Centurion is tested to double its pressure rating.



COMPATIBILITY

IPEX Centurion is manufactured with a cast iron outside diameter (CIOD) so it is compatible with much of the existing older infrastructure of iron pipes. In addition, IPEX Centurion can be field cut, which means unexpected changes in the field can be accommodated quickly, without having to wait for new shop drawings. IPEX Centurion Fittings are manufactured using sections of AWWA C905 pipe, overwrapped with a layer of fibre reinforced plastic (FRP). While IPEX Centurion is compatible with iron fittings, IPEX recommends the use of IPEX Centurion fittings exclusively with IPEX Centurion pipe.



MUNICIPAL PRESSURE PIPING SYSTEMS

IPEX Centurion® and Blue Brute® Pressure Piping Systems



PVC Pressure Systems manufactured to AWWA and CSA Standards

**IPEX Centurion® 14" – 48" (350mm – 1200mm),
AWWA C905 and CSA Standards**

**Blue Brute® 4" – 12" (100mm – 300mm),
AWWA C900 and CSA Standards**

Designed for municipal applications, IPEX Centurion® and Blue Brute® systems deliver superior strength with corrosion resistant performance and the ability to flex without damage.

IPEX municipal pressure piping systems are made with a high-strength, high-impact PVC compound, allowing them to perform even under high traffic loads and deep burial conditions.

For applications involving potable water, irrigation systems, or sewage forcemains, IPEX municipal systems offer the lowest break rate of any pipe material.

Blue Brute fittings are injection molded and are even tougher than the pipe. Injection molded Blue Brute fittings have a wall thickness 125% larger than SDR18 pipe, and custom-made fabricated fittings are wrapped with a tough layer of fiberglass for extra protection.

Proven in tough North American climates for over 50 years, IPEX PVC pipe, fitting and valve systems have an established track record of performance.

IPEX CENTURION®

BLUE BRUTE®



Products are manufactured by IPEX Inc.
and distributed in the United States by IPEX USA LLC.
Centurion® and Blue Brute® are trademarks
of IPEX Branding Inc.



Canadian Customers call IPEX Inc.

Toll Free: (866) 473-9462
www.ipexinc.com

US Customers call IPEX USA LLC

Toll Free: (800) 463-9572
www.ipexamerica.com

Key features include:

- **Corrosion-proof Performance**

IPEX Centurion and Blue Brute systems are immune to corrosion from aggressive soils and galvanic action.

- **Superior Hydraulics**

The glass-like finish of PVC reduces friction losses and eliminates the tuberculation common in iron pipes. As a result, pumping costs are reduced and water quality is maintained.

- **Cast Iron Outside Diameter (CIOD)**

Blue Brute and IPEX Centurion systems are manufactured with a cast iron outside diameter (CIOD). This is compatible with waterworks valves, appurtenances and restrainers.

- **Bottle-tight Joints, Removable Gaskets**

IPEX's patented gasket system not only withstands many times the rated system pressure, but also withstands full vacuum pressures. The unique removable gasket system allows special oil-resistant (nitrile) gaskets to be easily installed when working in contaminated soils.

- **Third-party Certification**

All IPEX municipal systems are third-party certified as applicable. In addition, IPEX Centurion and Blue Brute systems have Factory Mutual approval and Underwriter's Laboratories (ULI and ULC) listings.

Pressure Classes vs. Pressure Ratings

Water distribution systems normally consist of smaller diameter pipes 4" - 12" (100 mm – 300 mm) with many connections, taps, bends, valves, hydrants and other appurtenances. As a result, pipes in this size range are referred to by their pressure class. Pressure classes are defined in AWWA C900 and include a 2.5:1 safety factor for pressure, and a 2 ft/s (0.6 m/s) guideline for surge allowance. IPEX's Blue Brute adheres to this standard.

Conversely, larger diameter transmission pipes 14" - 48" (350 mm - 1200 mm) are grouped by pressure rating. A pressure rating as defined in AWWA C905 includes a 2:1 safety factor, which is more appropriate for larger diameter pipes. IPEX Centurion conforms to this standard.

AWWA C900 governs smaller water distribution systems pipes, while AWWA C905 governs larger diameter transmission pipe. All sizes adhere to the CSA B137.3 standard which recommends a 2:1 safety factor for both distribution and transmission applications.

Pressure Classes and Ratings

Note that these classes and ratings are extremely conservative. For instance, the minimum burst pressure for IPEX DR 18 pipe is 755 psi, but the pipe routinely withstands over 1000 psi.

Dimension Ratio	Pressure Class	Pressure Rating
14	200	305
18	150	235
25	100	165
32.5	N/A*	125
41	N/A*	100
51	N/A*	80

*Not manufactured in 4" - 12" (100 mm – 300 mm) sizes

Canadian Customers call IPEX Inc.
Toll Free: (866) 473-9462
www.ipexinc.com

US Customers call IPEX USA LLC
Toll Free: (800) 463-9572
www.ipexamerica.com

IPEX Fusible

CIOD & IPS: 100mm - 900mm (4"-36")

IPEX has introduced new Fusible Brute and Fusible Series PVC pipes. By combining the mechanical properties of PVC with an innovative, patentpending butt fusion process, IPEX provides the only available method of installing a continuous, monolithic, fully restrained PVC pipe system. Capable of being used in a variety of trenchless or conventional direct bury applications, Fusible PVC™ pipe systems have been installed at numerous sites throughout the United States, Canada and Mexico for both pressure and non-pressure installations in the water and sewer industries.



With PVC's proven long service life, Fusible Brute (CIOD) and Fusible Series (IPS) pipes are available in sizes ranging from 100mm (4") to 900mm (36") with larger sizes in development. The proprietary PVC formulation, fusion process as well as our licensing and training program allow for the consistent, reliable fusion of Fusible Brute and Fusible Series pipes to create piping systems of unparalleled strength.

ADVANTAGES

- **PVC is the most widely installed material in water systems today**
- **Greater pull force rating than HDPE and greater pull force rating than other PVC systems**
- **Lower installation costs versus HDPE due to lighter weight and reduced OD dimensions**
- **Creates gasket-free joints**
- **Has excellent abrasion and scratch-resistant properties**
- **Continuous pull-in lengths of over 1500 meters have been achieved**
- **Higher flow rates**
- **Connect directly to existing PVC systems for material consistency**
- **Uses standard CIOD or IPS fittings**
- **Creates monolithic, fully-restrained pipe systems**



Fusible PVC™ Pipe for Trenchless Applications



IPEX FUSIBLE™

**FUSIBLE BRUTE™
FUSIBLE SERIES™**



M U N I C I P A L S Y S T E M S

FUSIBLE PVC™ PIPE FOR HDD AND OTHER TRENCHLESS APPLICATIONS

- 100mm – 900mm (4" – 36")
CIOD & IPS Sizes
- 12.2m (40 ft) lengths



IPEX

We build tough products for tough environments®

IPEX FUSIBLE™

GO TRENCHLESS WITH PVC™



IPEX has introduced new Fusible Brute™ and Fusible Series™ PVC pipes. By combining the

mechanical properties of PVC with an innovative, patent-pending butt fusion process, IPEX provides the only available method of installing a continuous, monolithic, fully restrained PVC pipe system.

Capable of being used in a variety of trenchless or conventional direct bury applications, Fusible PVC™ pipe systems have been installed at numerous sites throughout the United States, Canada and Mexico for both pressure and non-pressure installations in the water and sewer industries.

With PVC's proven long service life, Fusible Brute (CIOD) and Fusible Series (IPS) pipes are available in sizes ranging from 100mm (4") to 900mm (36") with larger sizes in development. The proprietary PVC formulation, fusion process as well as our licensing and training program allow for the consistent, reliable fusion of Fusible Brute and Fusible Series pipes to create piping systems of unparalleled strength.

The Fusion Process

Fusible Brute and Fusible Series PVC pipe have distinctive properties allowing for full strength butt fusion joints. While other thermoplastic materials have been fused routinely, the patent-pending fusion process incorporates a proprietary PVC formulation and a

unique combination of heat, pressure and time, using slightly modified standard industry fusion machines.

All fusion times are comparable to other thermoplastic materials. All joints are fully restrained. Testing performed in accordance with ASTM D-638 methods, demonstrates that the tensile strength of the fused joint equals the tensile strength of the pipe.

Installation Methods:

- Horizontal Directional Drilling (HDD)
- Sliplining
- Pipe Bursting
- Direct Bury

Applications:

- Water Mains
- Sanitary Sewers
- Process and Raw Water
- Reclaimed Water
- Storm Drains

Pipe Specifications:

- Meets CSA B137.3, AWWA C900, AWWA C905, NSF-61 and ASTM cell classification 12454
- Available in CIOD and IPS sizes
- 12.2m (40') lengths



FUSIBLE BRUTE™
FUSIBLE SERIES™

PRESSURE RATINGS

FUSIBLE BRUTE™ (CIOD)

Dimension Ratio	Pressure (psi)
DR 14	305
DR 18	235
DR 25	165
DR 32.5	125
DR 41	100

FUSIBLE SERIES™ (IPS)

Dimension Ratio	Pressure (psi)
DR 21	200
DR 26	160

FEATURES & BENEFITS

- ✓ PVC is the most widely installed material in water systems today
- ✓ Greater pull force rating than HDPE
- ✓ Greater pull force rating than other PVC systems
- ✓ Reduced wall thickness relative to HDPE yields more flow and less material for given pressure class
- ✓ Lower installation costs versus HDPE due to lighter weight and reduced OD dimensions
- ✓ Creates gasket-free joints
- ✓ Has excellent abrasion and scratch-resistant properties
- ✓ Continuous pull-in lengths of over 1500 meters have been achieved

ADVANTAGES

- ◆ Higher flow rates
- ◆ Connect directly to existing PVC systems for material consistency
- ◆ Uses standard CIOD or IPS fittings
- ◆ Creates monolithic, fully-restrained pipe systems

PROJECTS

Tunney's Pasture Potable Water Main, Ottawa, Ontario

305m (1,000 LF) of 300mm (12") DR18,
110m (360 LF) of 400mm (16") DR25



Fusion Set-Up



Cold Weather Fusion at -14°C (6°F)

Potable Water Main, Burlington, Ontario

609m (2,000 LF) of 200mm (8") DR14,
183m (600 LF) of 200mm (8") DR14



Insertion into Entrance



Expansion Head & Pull Head

New Supply Pipeline, Sooke, BC

3,140m (10,300 LF) of 600mm (24") DR32.5



4m (14 LF) Right of Way



Pipe Pulled In

Distribution Line for City of Richmond, Richmond, BC

700m (2,300 LF) of 150mm (6") DR18



Fusing on Street



HDD Pipe Insertion

TerraBrute CR

4" - 12" (100mm - 300mm)

Engineered for Horizontal Directional Drilling (HDD) and other trenchless applications, TerraBrute® CR is a 100% non-metallic, AWWA C900 PVC pressure pipe system. Non-corroding and installation friendly, TerraBrute CR allows you to standardize on PVC throughout your potable water and sewer infrastructure. Whether you're using open-cut or trenchless methods, there are no more problems matching materials and couplings. No more butt fusion equipment headaches. No more surprises.



TerraBrute CR's patented non-metallic "ring-and-pin" gasketed joint design outperforms all other restrained PVC pipe joints on the market, providing more than twice the pull strength of other HDD systems – up to 120,000 lbs. for 300mm / 12" pipe. Unlike competing square-shoulder designs, TerraBrute CR's rounded bell shoulders slide by roots, rocks and other debris that can protrude into the borehole. And unlike HDPE, TerraBrute CR requires no relaxation time before installation of fittings or services.

Standards

AWWA C900

TerraBrute is made with pipe conforming to AWWA C900, however once the pipe is grooved on the spigot end its dimensions do not match those published in the C900 standard. Because of this small dimensional difference the pipe, once grooved, does not strictly conform to the C900 standard. It is important to note however, that TerraBrute is subjected to the same testing program as IPEX's Blue Brute (C900) pipe.

CSA B137.3

TerraBrute is made from stock certified to CSA B137.3.

NQ 3624-250

Factory Mutual and Underwriter's Laboratories TerraBrute is made from starting stock that is **Factory Mutual, ULC** and **ULI** Approved



PVC Piping Systems for HDD and Other Trenchless Applications



TerraBrute® CR

M U N I C I P A L S Y S T E M S

AWWA C900 PRESSURE PIPE
SYSTEMS FOR POTABLE WATER
AND SEWER APPLICATIONS

100mm – 300mm
4" – 12"



IPEX

We Build Tough Products for Tough Environments®

TERRABRUTE® CR TRENCHLESS

THE MISSING LINK IN YOUR TOTAL PVC PIPING SYSTEM

TOTAL PVC PIPING SYSTEM ENGINEERED FOR HDD

Engineered for Horizontal Directional Drilling (HDD) and other trenchless applications, TerraBrute® CR is a 100% non-metallic, AWWA C900 PVC pressure pipe system. Non-corroding and installation friendly, TerraBrute CR allows you to standardize on PVC throughout your potable water and sewer infrastructure. Whether you're using open-cut or trenchless methods, there are no more problems matching materials and couplings. No more butt fusion equipment headaches. No more surprises.

HIGHEST PULL STRENGTH AVAILABLE

Developed in consultation with leading trenchless technology research experts, and rigorously tested in the field, TerraBrute CR trenchless PVC pressure pipe easily withstands the high tensile and bending forces that occur during HDD and other types of trenchless installation.

TerraBrute CR's patented non-metallic "ring-and-pin" gasketed joint design outperforms all other restrained PVC pipe joints on the market, providing more than twice the pull strength of other HDD systems – up to 120,000 lbs. for 300mm / 12" pipe. Unlike competing square-shoulder designs, TerraBrute CR's rounded bell shoulders slide by roots, rocks and other debris that can protrude into the borehole. And unlike HDPE, TerraBrute CR requires no relaxation time before installation of fittings or services.

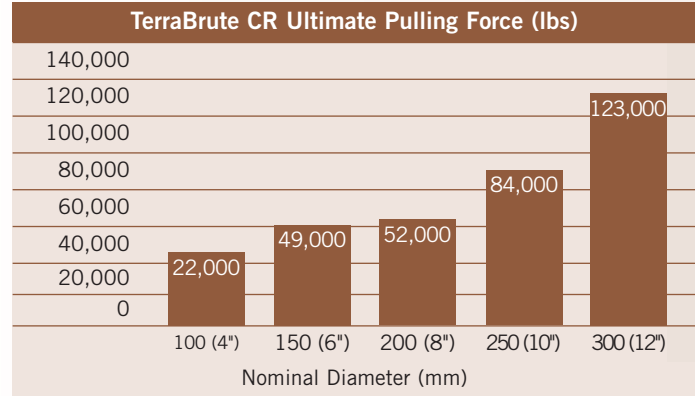

These ultimate load values were calculated using a semi-empirical design method derived at the University of Western Ontario and verified by laboratory testing. A safety factor of 2:1 should be applied to account for the combined tensile and bending loads associated with HDD applications.

Dimensions of TerraBrute CR Pipe						
Nominal Diameter		Pressure Rating (2:1 safety factor)	Max Outside Diameter (Bell OD)		Avg Internal Diameter	
mm	in		mm	in	mm	in
100	4	305	165	6.49	104	4.09
150	6	305	230	9.06	149	5.87
200	8	235	288	11.33	204	8.03
250	10	235	355	14.00	250	9.84
300	12	235	416	16.36	297	11.69

TerraBrute CR's larger internal diameters, compared to HDPE pipe, provide the same hydraulic performance usually with one size smaller pipe, saving on material costs.

“TerraBrute CR is the result of many years of research into the use of PVC pipes in HDD applications. The new non-corroding, locking joint design enables TerraBrute CR to enter new applications while maintaining the high tensile strength and bending radius of the original TerraBrute.”

Dr. Erez Allouche, Louisiana Tech University

TerraBrute® CR is manufactured from pipe certified to the following standards:



CORROSION RESISTANT

The new, non-metallic, "ring-and-pin" configuration of TerraBrute CR PVC pressure pipe offers complete corrosion resistance. The plastic "ring" is designed as two half rings for ease of installation and comes complete with the "pins" ready for insertion creating a strong, locking joint.

PROVEN PERFORMANCE

Pressure rated in excess of 200 psi, TerraBrute CR delivers the superior strength and corrosion resistance you've come to expect from our Blue Brute pressure pipe, along with the ability to absorb the underground shear and flexure stresses that occur in buried applications.

PROVEN COMPATIBILITY

TerraBrute CR trenchless PVC pipe is designed for total compatibility with your municipal system. Connections can be made with standard PVC CIOD fittings, direct tapped couplings or standard service saddles. Repair and handling techniques are the same as for any AWWA PVC pressure pipe.

PROVEN JOINING SYSTEM

Based on our gasketed bell and spigot design, proven through years of service in the field, the TerraBrute CR joint is rated at many times the pressure rating of the pipe. And unlike competing coupling joints, the TerraBrute CR joint has been specially engineered to deliver the highest pull strength safety factors in the industry for HDD applications.

FAST AND EASY JOINT ASSEMBLY

Unlike butt fusion or electrofusion joining methods used with HDPE pipe, TerraBrute CR requires no expensive equipment or special installer training. Because pipe segments are assembled during pullback operations, pipe stringing is eliminated. Assembly time for a 300mm / 12" TerraBrute CR joint is typically less than five minutes.

TerraBrute® CR

NEW NON-METALLIC "RING AND PIN" GASKETED JOINT DESIGN

Extended
Lip Bell

Plastic Ring
for Pins

Non-metallic
Pins

Grooved and
Thickened
Spigot

Inner Groove

Insertion Line

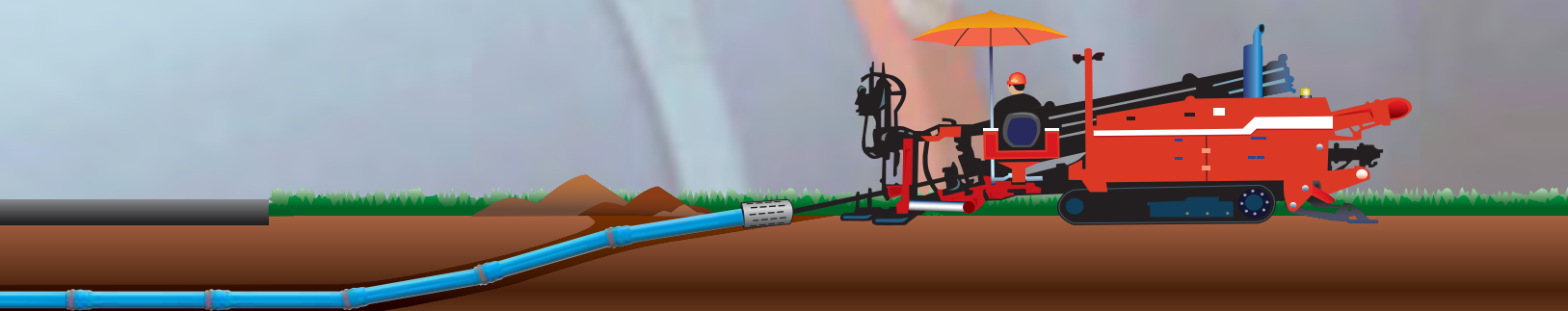
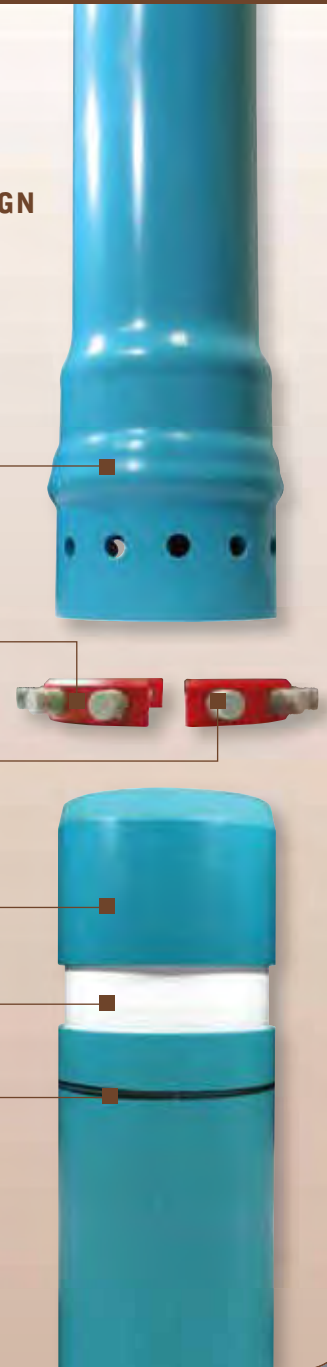

IDEAL TERRABRUTE CR APPLICATIONS

BRIDGE CROSSINGS

TerraBrute CR's unique "new non-metallic ring-and-pin" joint design provides for easy installation in non-HDD applications where traditional butt fusion techniques would be difficult – such as this span of suspended pressure pipe installed beneath a busy roadway bridge.



ROAD CROSSINGS

TerraBrute CR is ideally suited for short drilling projects where existing structures cannot be disturbed – such as under busy highways, roads and intersections where you connect to PVC pipes.



URBAN CENTERS

Because TerraBrute CR can be assembled segmentally just before entering the borehole, projects take up less space in restricted urban areas, compared to the long strings of pipe typical with conventional PVC and HDPE installations.



JOINT ASSEMBLY

1 Lubricate and assemble joint as for standard PVC pressure pipe.



2 Insert spigot up to the insertion line, aligning the internal ring and the pin holes.



3 One Ring at a time, place ring over pin holes and tap pins in until they bottom out on the inner groove.



4 Ready to begin pulling pipe.



Bionax PVC0

CIOD & IPSOD: 4" - 12" (100mm - 300mm)

Imagine a pipe with all the benefits associated with conventional PVC, yet dramatically stronger and more impact resistant.



Bionax is a molecularly-enhanced PVC pipe designed for water mains, sewage forcemains, irrigation lines and industrial process piping. Made from biaxially-oriented PVC material, Bionax has almost double the strength of conventional PVC and three times the impact absorption capability. Using a revolutionary new orientation process, this ultra high-tech process orients the PVC molecules both in the axial and circumferential directions (biaxial orientation). The result is a pipe with enhanced toughness and flexibility. Bionax is specially engineered to withstand the rigors of today's installations. With less construction inspection, and less regular maintenance, the market is calling for a pipe that is more robust, stronger and easier to install. Bionax delivers on all three counts.

The First Biaxially-Oriented PVC Pipe for Municipal Applications

Bionax's biaxial orientation dramatically enhances the pipe properties that are important to municipal designers:

- Larger internal diameters increase flow rates and reduce pumping costs
- Higher cyclic fatigue resistance for forcemain and irrigation applications
- Reduced surge pressure



A Revolution in PVC Toughness & Flexibility

BIONAX™



M U N I C I P A L S Y S T E M S

MOLECULARLY ENHANCED PVC PRESSURE PIPE FOR UNDERGROUND WATER AND SEWER APPLICATIONS

- 4"-12" (100mm-300mm)
CIOD & IPSOD Sizes
- Operating Pressures 235psi CIOD,
160 psi IPSOD

IPEX

We build tough products for tough environments®

BIONAX™

A REVOLUTION IN STRENGTH, TOUGHNESS AND FLEXIBILITY

Imagine a pipe with all the benefits associated with conventional PVC, yet dramatically stronger and more impact resistant.

Introducing Bionax, a molecularly-enhanced PVC pipe designed for water mains, sewage forcemains, irrigation lines and industrial process piping. Made from biaxially-oriented PVC material, Bionax has almost double the strength of conventional PVC and three times the impact absorption capability. While millions of feet of earlier versions of oriented PVC have been installed, Bionax is manufactured using a revolutionary new orientation process, previously unavailable in North America. This ultra high-tech process orients the PVC molecules both in the axial and circumferential directions (biaxial orientation), resulting in a pipe with enhanced toughness and flexibility even when compared to earlier versions of oriented PVC.

Bionax is specially engineered to withstand the rigors of today's installations. With less construction inspection, and less regular maintenance, the market is calling for a pipe that is more robust, stronger and easier to install. Bionax delivers on all three counts.

The First Biaxially-Oriented PVC Pipe for Municipal Applications

Bionax's biaxial orientation dramatically enhances the pipe properties that are important to municipal designers:

- Larger internal diameters increase flow rates and reduce pumping costs
- Higher cyclic fatigue resistance for forcemain and irrigation applications
- Reduced bend radius when compared to standard PVC pipe

Things are not always perfect in the field. Pipe can be impacted by equipment, bedded with sharp stones and boulders, or even pierced by directional drilling equipment. Bionax is designed to withstand even the most violent impact events, and if pierced by a directional drill or "torpedo" type piercing tool, will exhibit only a localized failure. The unique layered material structure that resists impacts also stops cracks before they propagate.



Impact Resistant

With three times the impact strength of regular PVC, Bionax can handle the most punishing storage, handling and construction site conditions.



Tapping Strength

Bionax's unique structural design allows tapping holes to be drilled close together without the risk of splitting or cracking.



Pressure Tough

Bionax's unique molecular reinforcement gives it the ability to withstand extreme internal pressures and deform instead of failing.



FEATURES & BENEFITS

- ✓ **Circumferential Tensile Strength** – Bionax has almost double the tensile strength of conventional PVC (12,100 psi vs. 7,000 psi). This higher strength results in larger inside diameters, improving the hydraulics of the pipe.
- ✓ **Impact Strength** – Bionax provides triple the impact strength of standard PVC pipe. PVC pipe can withstand extreme jobsite conditions with no damage.
- ✓ **Crack Resistance** – PVC's laminar structure prevents crack propagation, preventing damage to the pipe.
- ✓ **Longitudinal Tensile Strength** – Bionax has higher tensile strength in the axial direction, which allows a tighter bend radius than other materials.
- ✓ **Certification** – Bionax is the most certified product on the market, NSF certified to meet AWWA and ASTM standards.

Although this extreme punishment shows how tough Bionax really is, we do not recommend this type of abuse for any real project – please follow our installation procedures.

CERTIFIED TOUGH

Every length of Bionax is hydrotested to AWWA standards before being shipped. In fact IPEX is the only manufacturer to have third-party certification (by NSF) to meet the stringent AWWA standards. This rigorous testing means Bionax will work as tough on your job site as it does in our labs.

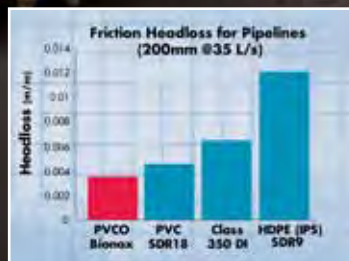

Excellent Hydraulics

Bionax's smooth inside surface and larger ID means less friction headloss versus other materials. The reduced pumping costs and energy use are good for the environment.

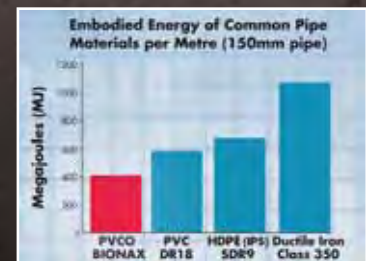

The Green Solution

Bionax has the lowest embodied energy per metre than any other piping material. Taking less energy to manufacture, Bionax has the lowest carbon footprint of any piping product available.



Lightweight & Easier to Handle

40% lighter than conventional PVC, Bionax is safer and easier to carry. This means less equipment is required and installation is fast and efficient. Bionax's increased flexibility means a reduced bending radius that allows it to fit around gradual curves. In fact, Bionax is so light and flexible that several joined lengths can be lifted as a single unit and installed in a trench, further speeding installation.

Reduced Maintenance & Pumping Costs

Bionax's increased strength allows higher inside diameters for the same pressure rating, reducing pumping costs. Bionax's smooth inside surface maintains its excellent hydraulic properties virtually forever with extremely low maintenance costs, saving energy associated with pumping and maintaining its superior flow profile.

Manufacturing Consistency & Quality

Bionax's ultra high-tech manufacturing process ensures that the pipe will meet the toughest standards. In fact, the initial stock pipe must be flawless in order to survive the orientation process – in essence, the process acts as its own quality control. Bionax is 100% I.D. and O.D. controlled, meaning that its tolerances are much tighter than conventional pipe.

Joining Methods

Bionax's standard joining method uses easy-to-assemble gasketed joints. No special training is required to install Bionax as the procedure is virtually identical to standard PVC pipe. In addition, research has shown that Bionax can be successfully solvent cemented for above ground applications. This brings the benefits of a super-impact resistant pipe to an entirely new set of applications.

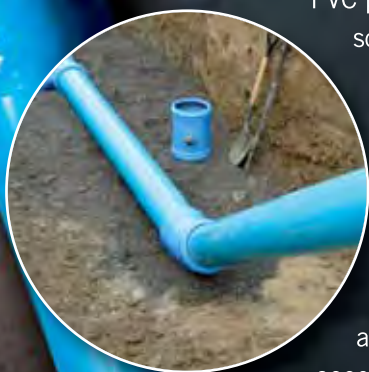

Integrated Total PVC Solutions

Typical of any IPEX piping system, Bionax offers a totally-integrated solution. The entire end-to-end system integrates seamlessly and is compatible with regular C900 and C907 fittings. When you purchase Bionax, you get everything – all the pipe and fittings – you need to get the job done. And since it comes from IPEX, you also get the peace of mind knowing your system is supplied by a single trusted and accountable source who is guaranteed to stand behind you and your piping system.



APPLICATIONS

Water Mains

Sewage Force Mains

Irrigation Lines

Industrial Process Piping



BIONAX™

MOLECULARLY ENHANCED PVCO PIPE

While biaxial orientation isn't a new process, it's been difficult to produce efficiently and reliably in high volumes. Thanks to a breakthrough in innovative manufacturing, IPEX now uses the most advanced process in the plastics industry to biaxially orient PVC molecules and produce the lightest, strongest pipe available.

In the past, oriented PVC was expanded in a mold, resulting in orientation in only one direction. Now biaxial orientation is achieved by stretching pipe over a mandrel at tightly-controlled temperatures and stress levels. The result is a pipe with dramatically-enhanced properties both in the circumferential direction (increased hoop stress capability) and in the longitudinal direction (higher impacts, point loading and lower bending radius). More importantly, Bionax's manufacturing process consistently maintains these qualities with a continuous process, rather than using older batch processing technology.

While these cutting-edge manufacturing techniques are expensive, they result in the strongest, toughest and most consistent high-quality pipe available on the market today.



Stretching regular PVC pipe biaxially in both the hoop and axial directions—lengthways and sideways—over a mandrel after the pipe is extruded dramatically improves the performance of PVC material.

REGULAR PVC



Regular PVC is manufactured in a single layer.

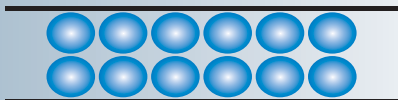

When PVC pipe is extruded in the traditional way, a more or less spherical molecular structure results, requiring thicker walls to provide the necessary strength.

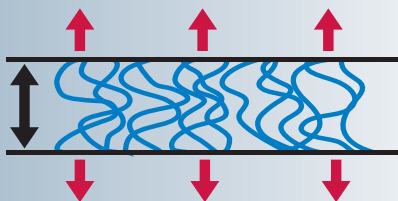

Because they're unaligned, the molecules within regular PVC react to force in a general, haphazard direction.

BIONAX™



Due to biaxial molecular orientation during the manufacturing process, thin stratified layers are formed within the PVCO, resulting in higher impact strength even under extreme pressure.

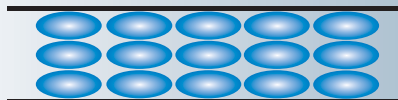

As the PVC is stretched, so are the spherical molecules, allowing more of these elongated molecules to fit into a single layer than regular PVC. This gives the material a higher molecular density and makes it tougher.

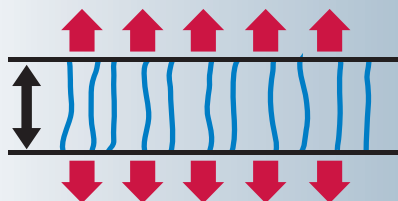

Biaxial stretching creates a molecular orientation in which the molecules can be aligned in the direction of the expected load, resulting in superior force resistance.

BIONAX™



CIOD PIPE

Nominal Sizes	4" (100mm)	6" (150mm)	8" (200mm)	10" (250mm)	12" (300mm)
Outside Diameter	4.80" (122mm)	6.90" (175mm)	9.05" (230mm)	11.10" (282mm)	13.20" (335mm)
Pressure Rating	235 psi at 73°F				

Available in 20 ft. lengths



IPSOD PIPE

Nominal Sizes	4" (100mm)	6" (150mm)	8" (200mm)	10" (250mm)	12" (300mm)
Outside Diameter	4.50" (114mm)	6.63" (168mm)	8.63" (219mm)	10.75" (273mm)	12.75" (324mm)
Pressure Rating	160 psi at 73°F				

Available in 20 ft. lengths

Experience Bionax's revolutionary performance on this CD-ROM.

Cycle Tough

Pipe: 100mm - 400mm - Injection Molded Fittings: 40mm - 200mm

CycleTough™ IPS piping systems are specifically designed for irrigation systems and sewer forcemains. The constant cyclic surging that is associated with these applications demands a tough pipe, and more importantly, a specially engineered fitting.



Unlike many competing fittings, CycleTough fittings are made with a longlife compound that extends service by 25%. In addition, CycleTough fittings have been engineered using the latest techniques in Finite Element Analysis (FEA), ensuring problem-free performance for the long haul.

ADVANTAGES

High Impact Strength

CycleTough systems have a 2:1 safety factor for long-term pressures, and over 3.2:1 for temporary surges. CycleTough systems easily withstand surges over 600 psi.

Fittings Engineered

CycleTough fittings are engineered for versatility and reliability. Their unique design features extra material added for reinforcement to withstand the stresses imposed by tough irrigation and forcemain applications.

Iron Pipe Size Outside Diameter (IPSOD)

CycleTough systems are made with an IPSOD, which is the same outside diameter configuration as schedule piping and most steel process piping.

Bottle-tight Joints, Removable Gaskets

IPEX's patented gasket system not only withstands many times the rated system pressure, but also withstands full vacuum pressures. The unique removable gasket system allows special oil-resistant (nitrile) gaskets to be easily installed when working in contaminated soils.

Third-party Certification

All CycleTough systems are certified to CSA B137.3. Third-party certification verifies a system will perform as expected, meeting all applicable standards.

